

# A Review of Control Strategies for Microgrid with PV-Wind Hybrid Generation Systems

Linus A. Alwal, Peter K. Kihato and Stanley I. Kamau

E-mail: <sup>1</sup>[laloo@jkuat.ac.ke](mailto:laloo@jkuat.ac.ke) <sup>2</sup>[pkihato@jkuat.ac.ke](mailto:pkihato@jkuat.ac.ke) <sup>3</sup>[skamau@eng.jkuat.ac.ke](mailto:skamau@eng.jkuat.ac.ke)

**Abstract**— The concept of microgrid has been attracting a lot of interest among researchers and investors over the last decade. This is because it offers a promising technology towards the utilization of distributed renewable energy resources, notably Photovoltaic (PV) and Wind hybrid generation systems in islanded or grid-connected mode. The main problem currently facing utilization of PV-Wind based distributed generation systems is that of consolidating the power and controlling its voltage and frequency levels on the right scale for either off-grid or on-grid utilization. This is due to their intermittency in power outputs and geographical fragmentations. Thus there is need to coalesce such power units into microgrids with reliable storage systems which can be better managed using a microgrid control system.

This study aims at reviewing the advances made towards the utilization of microgrid control systems incorporating PV-Wind generation units with emphasis on the applicable microgrid control strategies and principles. Based on the review conducted, it was noted that every control strategy has its merits, demerits, level of efficiency and cost. Further, to address the control challenges of the PV-Wind hybrid generation system, a Multilevel Microgrid Control System (MMCS) utilizing appropriate artificial intelligence has been proposed. The research directions in this field are geared towards the use of artificial intelligence to optimize performance of the system.

**Keywords**— Control Strategies, Hybrid, Microgrid, PV-Wind

## I. INTRODUCTION

Nowadays, there are increasing needs to shift focus on power generation from the environmentally unfriendly conventional sources such as diesel or coal plants to the clean and renewable sources such as photovoltaic (PV) and wind [1]-[6]. However, the main bottleneck in the utilization of these renewable resources has been on the proper control and management of their power outputs as well as robust protection mechanisms. This is because owing to the intermittent nature of PV and wind resource, there is no guarantee that the needs of a given load or power system will be efficiently served [7], [8]. The control and protection problem is even more complicated when a hybrid of such sources is adopted. One solution to this has been on pooling together the resources into a microgrid. In its basic form, a microgrid may be viewed like a small local power system whose main objective is to serve or electrify remote communities [4], [5]. Microgrids can be operated in two modes:

grid-connected mode and islanded mode [9]-[13]. For efficient performance of a microgrid, a reliable microgrid control system with suitable control algorithms is required [14]-[18]. The aim of this study is to provide an overview of such control strategies which are applicable to a hybrid microgrid system. The control strategies and architectures reviewed include hierarchical control schemes, the conventional and modified droop control methods, model predictive control, nonlinear programming algorithms, artificial intelligence control methods, and commercial microgrid systems. Also, control design guidelines particularly those that contain renewable energy sources such as PV and wind in hybrid configuration are discussed. Further, based on the observed trends and gaps, a Multilevel Microgrid Control System (MMCS) utilizing suitable artificial intelligence has been proposed for PV-Wind hybrid generation microgrid system. The future research directions, challenges and conclusion are captured towards the end of the study. The subsequent sections of the paper are organized as follows: Section II presents Hybrid PV-Wind Microgrid System while Section III captures Existing Microgrid Control Strategies. In Section IV, Microgrid Challenges and Proposed Control Framework are presented. Finally, the review is wrapped up in Section V with Conclusions and Future Research.

## II. HYBRID PV-WIND MICROGRID SYSTEM

### A. Microgrid Control System (MCS)

A Microgrid Control System (MCS) is a supervisory based control architecture which enables efficient and cost effective utilization and integration of Distributed Energy Resources (DERs), loads and energy storage in a localized framework [19]-[22]. Fig. 1 shows a microgrid control system with solar PV and wind as the principal microsources [5]. A microgrid control system is required to regulate and optimize the utilization of power outputs from these sources which may be coupled directly to the DC bus at the point of common coupling (PCC) and subsequently to the AC bus via an inverter. The loads, classified as low priority, essential AC and dump, are connected to the load bus. The main roles of a microgrid control system are as follows [2]-[6]: First, is control of voltage and frequency for both grid-connected and islanded modes. Second, it provides efficient load sharing, co-ordination of DERs, and

Linus A. Alwal, Department of Electrical and Electronic Engineering, Jomo Kenyatta University of Agriculture & Technology (JKUAT), Kenya, (phone: +254729747653; e-mail: [laloo@jkuat.ac.ke](mailto:laloo@jkuat.ac.ke));

Peter K. Kihato, Department of Electrical and Electronic Engineering, JKUAT, Kenya (e-mail: [pkihato@jkuat.ac.ke](mailto:pkihato@jkuat.ac.ke));

Stanley I. Kamau, Department of Electrical and Electronic Engineering, JKUAT, Kenya (e-mail: [skamau@eng.jkuat.ac.ke](mailto:skamau@eng.jkuat.ac.ke)).

microgrid re-synchronization with the main grid. Third, it controls power flow between microgrid and main grid and also optimizes its operating cost. Finally, it appropriately handles transients and re-establishes prescribed conditions when transitioning between the modes.

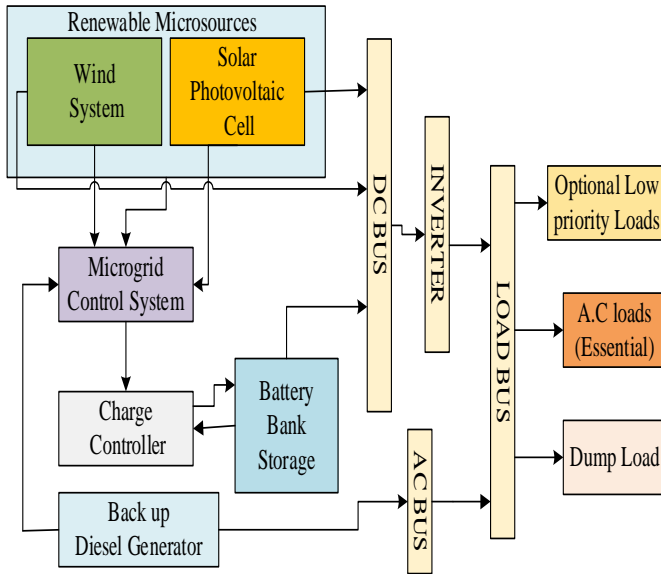

Fig.1 Block diagram of Microgrid Control System [5]

Two broad categories of microgrid on the basis of the type of power handled are AC microgrid and DC microgrid, which gives rise to AC and DC microgrid control techniques [2], [10], [11], [18] and [19]. On the other hand, in terms of the operation principle, microgrids can operate in two modes: grid-connected mode and islanded (off-grid) mode [15]-[18]. Based on the grid connection status of a microgrid, it can be categorized into two. First, as permanently islanded microgrid in which stand-alone networks serve as the sources for all of the locally generated power which in turn must be consumed by the loads in the isolated network. Second, is the grid-tied microgrid which is not only capable of generating power within its distribution networks but also import power from a utility source [18]. The former networks are typically found in remote areas or island communities where high transmission costs and losses render connection to the grid or bulk importation of fuel uneconomical. Further, renewable resources (wind, solar, hydro) should be available to make optimization of generation resources very desirable [1], [2] and [3].

### B. Photovoltaic and Wind Energy System

The modeling of a Hybrid PV-wind microgrid system shown in Fig. 1 can be done by considering the PV and wind energy systems separately. However, there is interdependency in the sizing, control setting and operation strategies [5]. Consequently, the choice among design possibilities of a given hybrid PV-wind system becomes quite challenging. The

important aspects of these systems are the power outputs as well as their equivalent circuit models.

The power generated from a PV system with respect to solar radiation (SR), denoted by  $P_{PV}$ , is given by (1).

$$P_{PV} = P_{STC} \frac{G_{ING}}{G_{STC}} (1 + k(T_C - T_Y)) \quad (1)$$

where  $P_{PV}$  is the power generated from a PV system,  $G_{ING}$  is the incident irradiance,  $P_{STC}$  and  $G_{STC}$  is maximum power and irradiance at standard test condition respectively,  $k$  is the temperature coefficient,  $T_C$  is the module temperature and  $T_Y$  is the reference temperature.

The power generated from a wind turbine (WT) unit,  $P_{WT}$  can be specified as a cubic function with respect to the wind speed at the monitoring station as in (2).

$$P_{WT} = \frac{1}{2} \rho \pi R^2 v^3 C_p \quad (2)$$

where  $P_{WT}$  is the power generated from a wind turbine (WT) system,  $R$  is the radius of the paddle of wind turbine,  $\rho$  is the air density of the monitoring area,  $v$  is the wind speed of power generation area and  $C_p$  is conversion efficiency of the wind power.

## III. MICROGRID CONTROL METHODS

### A. Hierarchical Control Schemes

The control objectives of AC and DC microgrids can be considered in terms of a hierarchical or multilevel control structure, which can be classified into three levels as: primary, secondary and tertiary control levels [2], [3]. This leads to a multilevel control structure shown in Fig. 2.

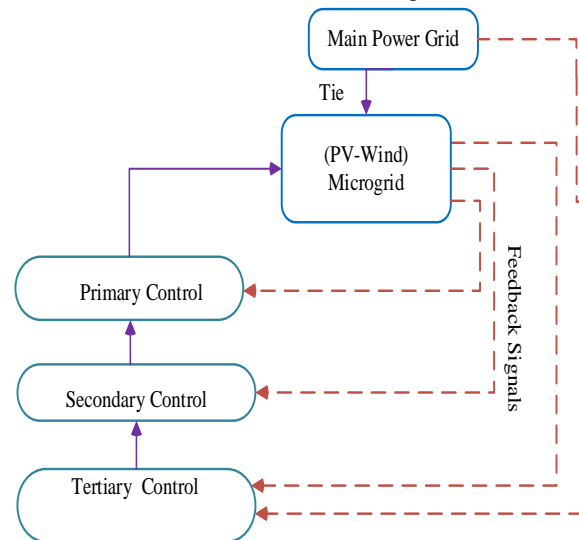

Fig.2 Hierarchical control levels of a microgrid [2]

The *primary control level* operates at the fastest timescale and encompasses the fundamental control hardware for executing the internal voltage and current control loops of the distributed PV-wind microsources. Consequently, it deals with local measurements and does not need a communication system. It is responsible for ensuring that the voltage and frequency are stabilized within the microgrid or when switching mode. It also

curtails the occurrence of circulating currents and provides a plug-and-play capability of the DERs. The need to provide independent active and reactive power sharing controls for the DERs is emphasized especially in the presence of both linear and nonlinear loads [2]. Principally, the most common strategies for active power and reactive power regulation are droop-based controls (voltage-reactive power and frequency-active power droop controls) [1]-[4].

The *secondary control* is utilized to compensate for the variations in voltage and frequency due to actions by the primary controls. However, this task becomes particularly challenging in stand-alone PV-Wind microgrids due to the presence of highly-variable sources [4], [5]. It can be realized using two main approaches: centralized and decentralized architectures, essentially defined depending on the position of the Microgrid Central Controller (MGCC) [4], [8]-[9]. Centralized control is characterized by complex central processing elements which are situated far away from the microsources. It uses a communication system such as a Microgrid Supervisory Control And Data Acquisition (MicroSCADA) which involves a central system, sensors and control devices [9], [12]. It is recommended for certain small microgrids with shared goals and thus should cooperate. However, with growth in microsources data, the centralized approach tends to be slower and may easily malfunction. Apart from creating a single point of failure to the microgrid system, it also hinders up-scaling and may be uneconomical. This is where the decentralized control, which favors the utilization of the proposed PV-wind microgrid, comes in. Decentralized control is preferred for microgrids of different vendors and which should make independent decisions pertaining to their operating conditions. In other words, decentralized microgrid control system incorporates an intelligent control for each microsource. It reduces the network complexity, allows easy scalability, improves power supply reliability, more economical and offers bi-directional power flow [9]. However, a disadvantage of this approach is the load-dependent frequency and amplitude deviations due to the utilization of the droop control method in primary control to manipulate the active and reactive power [8].

Finally, at the highest level and corresponding to the slowest timescale, is the *tertiary control* which manages the bidirectional power flow between the microgrid and the main grid thereby facilitating an economical and optimal operation of the hierarchical control system. For instance, in a case where the power generated in the microgrid surpasses the local power demand, which coincides with maximum absorption of power from PV and wind renewable resources, then the excess power is transmitted directly to the high-inertia DC system or to the main AC grid through an inverter [2].

As depicted in Fig. 3, a number of control techniques have been proposed in literature for the inner-loop control and primary control, deployed according to the characteristics of the microgrid [19]-[25]. The aim is to improve the power quality, disturbance rejection and voltage or current tracking of the inverter output [13], [26]. Some of the techniques applicable to PV-wind microgrid are discussed next.

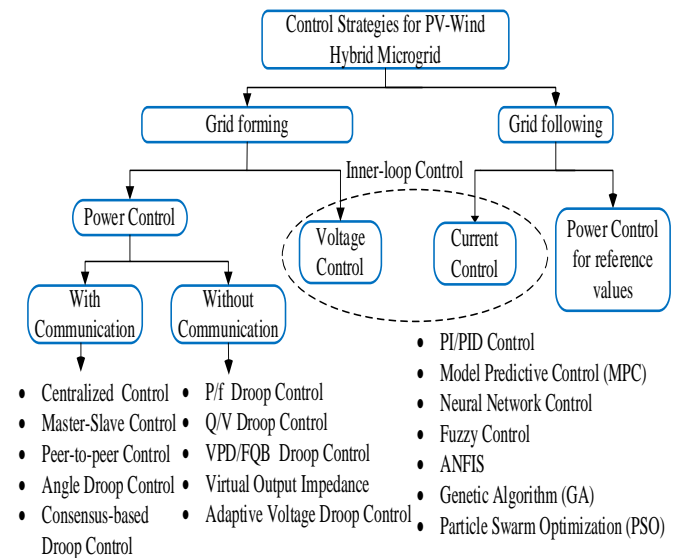

Fig.3 Inner-loop control and primary control techniques [13].

### B. Droop Control Methods

Conventional and modified droop control methods have been widely utilized in microgrid systems particularly for inner control loops/primary control [1]-[4], [8]-[11], [13]-[16], [24]. The design of droop controllers (conventional voltage and frequency droop controllers) can be conducted using appropriate and separate small-signal models [2]. Important to note is the prevailing basic trade-off between the time constant of the control system and the frequency regulation. In microgrids, this is mostly implemented either in active/reactive power (PQ) mode or voltage control mode.

- i. Active/reactive power (PQ) Control Mode: The microsource active and reactive power supply is regulated based on predetermined reference points as shown in Fig. 4. This is achieved using a current-controlled voltage source inverter (CCVSI) [2].

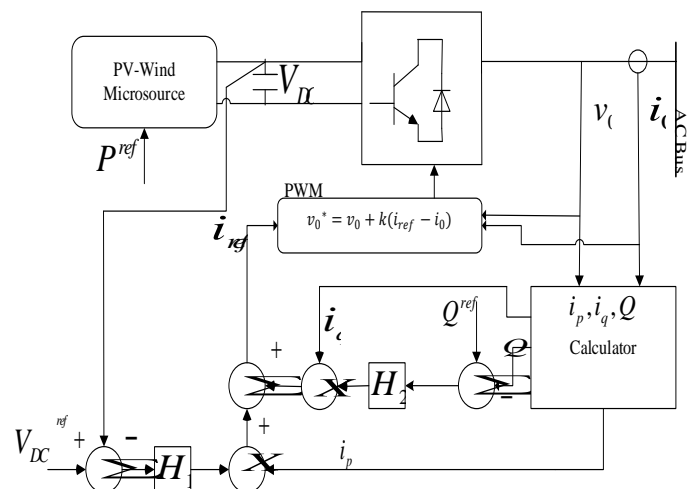

Fig.4 PQ control mode with active and reactive power references [2].

- ii. Voltage Control Mode (VCM): The DER functions as a voltage-controlled voltage source inverter (VCVSI), implying that the reference voltage  $v_0^*$  is obtained through

droop characteristics using the primary control as shown in Fig. 5. Such techniques are acquiring more attention as they are capable of emulating the behavior of a synchronous generator [16].

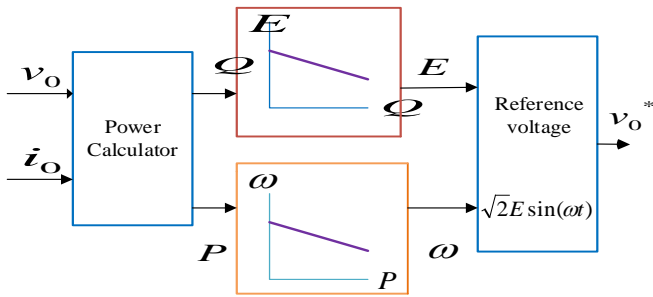

Fig.5 Determination of reference voltage for VCM [2]

The VCM nested voltage and current control loops is shown in Fig. 6 [2]. It is seen that such a control strategy injects the current signal as a feedforward term through transfer function. If this model were to be applied in small-scale islanded systems with PV-wind sources, the major concern would be on how to improve the power quality. This scenario is made even more challenging in presence of non-linear and single phase loads or the low inertia presented by the microgrid.

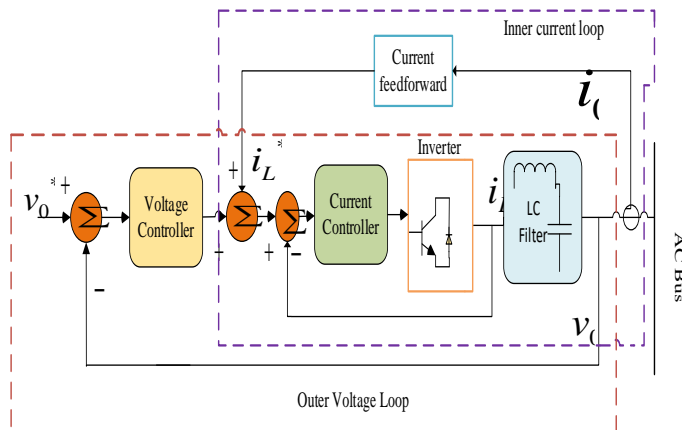

Fig.6 Voltage and current control loops in VCM [2]

One direct way to improve the power quality suggested in [2] and [13] is to modify the control structure by adopting a low pass filter both in the feedforward inner current loop as well as the feedback outer voltage loops which aids in the removal of harmonic contents. Contrary to the active load sharing technique, the conventional droop method can be implemented without any communication links, hence is more reliable. However, some of its shortcomings include [2], [13]-[16]:

- i. The approach handles only one control variable for each droop characteristic thus it is impossible to simultaneously achieve multiple control objectives.
- ii. Development of conventional droop method assumes that the effective impedance between the VCVSI and the AC bus is highly inductive. However, this assumption does not hold in microgrid applications where the low-voltage transmission lines are majorly resistive.
- iii. In a microgrid, frequency is a global quantity whereas the voltage is not. Consequently, for critical loads, the reactive power control may adversely affect the voltage regulation.

- iv. Further, for non-linear loads, the conventional droop method cannot distinguish the load current harmonics from the circulating current. This leads to distortion of the DER output voltage by the current harmonics.

The following techniques have been proposed to address the drawbacks of the conventional droop method by minimizing the total harmonic distortion (THD) [2], [13]-[16].

- i) *Adjustable load sharing method*-in which the time constant of the active and reactive controllers can be altered without affecting the DER voltage and frequency.
- ii) *VPD/FQB Droop method*-The voltage active power droop and frequency-reactive power boost (VPD/FQB) characteristics approach is proposed for tackling the challenges of predominantly resistive low-voltage microgrid lines. The VPD/FQB technique can also be altered to vary the controller time constant without changing voltage and frequency. However, it is highly dependent on system parameters thereby restricting its application. Moreover, it can malfunction when subjected to non-linear loads and thus cannot assure sustained voltage regulation. Fig. 7 a) and b) show voltage-active power droop characteristic and frequency-reactive power boost characteristic respectively [2].

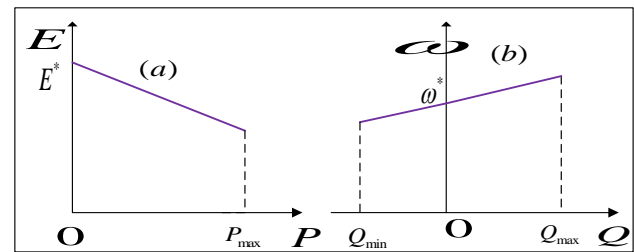

Fig.7 Low-voltage microgrids droop/boost characteristics [2].

- iii) *Virtual Frame Transformation Method*-The droop method with virtual power frame transformation utilizes an orthogonal linear transformation matrix to transfer the active/reactive powers to a new reference frame. This results to the powers being independent of the effective line impedance [2].
- iv) *Virtual Output Impedance*-which utilizes an intermediate control loop to vary the output impedance of the VCVSIs. This method mitigates against the dependency of the droop techniques on the system parameters and operates satisfactorily in the presence of non-linear loads. However, the method does not guarantee regulation of voltage. Also, adjusting the closed-loop time constant may cause undesired deviation in the DG voltage and frequency.
- v) Some other techniques proposed include *adaptive voltage droop control* and *non-linear load sharing* [2].

**C. Model Predictive Control and Nonlinear Programming**  
The Model Predictive Control (MPC) is presented in [4], [6], [19] and [20]. The MPC method uses a prediction model which is based on existing system knowledge and future predictions to determine the control variables in real-time (online) for every sampling period. From this, the minimal value of control variable in the predictive function is selected for the next

sampling period (time step) [6], [19]. Thus at every discrete time step, an optimization model which covers finite horizon is deployed to generate a control action sequence, from which often the first action is utilized. Using the renewed system state and future information, the system then moves to the next time step and the above computation is repeated [20]. Fig. 8 shows the principle of MPC which can be viewed as a closed-loop system due to continuous modulation of control variables to compensate for prediction inaccuracies.

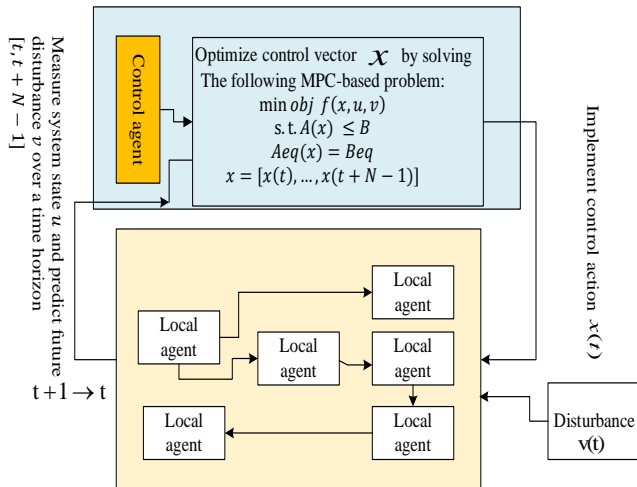

Fig.8 Principle of MPC [20]

The main components of the MPC scheme include:

- i) a control agent which optimizes control actions over a finite horizon based on a system-wide objective function;
- ii) multiple local agents to execute control actions;
- iii) possible disturbances that may influence the local implementation of control actions.

The MPC method can be realized in centralized or decentralized schemes. It has been widely used as an inverter control strategy [6] and to solve the problem of real-time economic dispatch and power exchange between the microgrid and the energy storage (ES) or utility system [19], [20]. In the case of a microgrid economic dispatch, microgrid Energy Management System (EMS) acts as the central control agent where the local agents include micro turbines, energy storage system and scalable load. The central control agent aims at minimizing the total operation cost by generating suitable reference points for all controllable units and also the optimal power exchange with the utility grid. These agents together maintain a global power balance by consistently responding to the coordinated energy management commands from the higher level EMS. Wind speed, load changes and power prices constitute uncertain disturbances and their predications are constantly updated by EMS.

One of the existing MPC methods for microgrids with distributed ES involves strategies considering only one ES system or aggregated multiple ES systems. This doesn't account for the power flows between various ES systems. The other category involves strategies based on non-convex optimization. For example, MPC based on non-linear programming (NLP) in unbalanced microgrids [4], [19]. However, if the problem is non-convex scalability is limited

and the available solvers are capable of only providing locally optimal solutions. Recursive dynamic programming (RDP), which produces a globally optimal solution, may be an alternative for the ES system optimal power flow problem. However, its numerical complexity increases with the number of ES systems [19].

In [19], a new convex MPC strategy is proposed for solving the dynamic optimal power flow problem between battery energy storage systems (BESS) distributed in an AC microgrid with intermittent PV generation. The problem formulation is based on a linear  $d-q$  reference frame VCM and linearized power flow approximations. The results indicated that the proposed control strategy approaches the performance of a strategy based on non-convex optimization, while minimizing the required computation time by a factor of 1000. Since the problem was solved as a convex quadratically constrained quadratic program (QCQP), for which fast and robust solvers exist, it is recommended for a real-time receding horizon MPC implementation [19]. The method takes into consideration line losses, voltage constraints and converter current constraints during the optimization. The implementation of MPC for solving nonlinear optimization problems at each time-step is called nonlinear MPC (NMPC) and is presented in [4].

In [9] utilization of *Multi-Agent System (MAS) based Control* strategy is presented. This is deployed in hierarchical control architecture when several microgrids organized into clusters are to be controlled. It is made up of four agents; control agent, DER agent, user agent and database agent. This approach offers flexibility in microgrid control in grid-connected or stand-alone mode as well as providing a seamless transition between the two modes.

#### D. Artificial Intelligence Control Methods

When PV-wind hybrid microgrid systems are to be implemented in remote areas which are ideal for stand-alone operation, it becomes challenging to acquire long-term weather data such as solar radiation and wind speed to aid in sizing. Consequently, artificial intelligence techniques such as artificial neural networks (ANN), fuzzy logic [FL], genetic algorithms (GA) and particle swarm optimization (PSO) become very useful in sizing stand-alone systems as compared with the conventional sizing method which is highly dependent on long-term weather data [5], [7], [21]-[23].

##### a) Genetic algorithm method

Genetic algorithm (GA) method is a search technique and is suitable for a complex problem such as a PV-wind hybrid system when other techniques do not offer acceptable solutions. In this case, the weather conditions are varying hourly and daily and thus will also be different for different seasons in a year. The deployment of GA method aids in obtaining the optimum number of facilities to use based on the hourly average metrological and load data collected, say over a few years, for simulation purposes [5].

##### b) Artificial Neural Networks (ANN)

Artificial Neural Network (ANN) has a self-learning feature which enables the algorithm to be easily developed for different operating conditions and grid disturbances [13]. However, it lacks performance in off-line training technique. In [21], the Lagrange programming neural network (LPNN) is used in a hybrid microgrid to achieve optimal scheduling and management. The objective function incorporated power generation cost, operation and maintenance cost, emission-control cost and fuel cost. The LPNN minimized the cost function and maximized the energy generated by the wind turbines (WTs) and photovoltaic cells (PVs). The energy stored into and supplied from the storage system was optimized too. Further, day-ahead prediction of renewable resources and load demand was obtained using the radial basis function neural network (RBFNN). The results of LPNN were compared with those of the basic PSO. It was observed that the LPNN was better than the PSO method. For instance, when the LPNN cost is \$274.64, the PSO cost is \$476.84, which is 1.74 times higher. This indicates clearly that the PSO is weaker in dealing with constrained problem [21].

#### c) Particle Swarm Optimization

The particle swarm optimization (PSO) method is reported in [5], [21] - [23] and can be used in optimal sizing of the hybrid energy systems. In [22], the PSO method is used to solve a day-ahead microgrid dispatch problem taking into account uncertainties which are associated with energy production by the PV and wind sources. The stated uncertainties were modeled by incorporating a robust approach in PSO and the method tested on 21-bus microgrid (MG). From the test results, it was observed that the robust optimization approach (PSO) was more advantageous (17%) compared to the deterministic optimization. Although the execution time of PSO (2360 seconds) is comparatively high, it was acceptable for the day-ahead decision time period.

The success of PSO scheme is also reported in [23], where it is used in the design and optimization of a hybrid microgrid system (HMGS) using the solar and wind meteorological data. This study applied PSO in sizing of wind turbines (WT), photovoltaic (PV) module, battery energy storage system (BESS) and diesel generator. Based on simulation results and the sensitivity analysis conducted, it was observed that the PSO technique achieved the best size and configuration of PV-wind based HMGS.

#### d) Fuzzy Based Controllers

The Fuzzy Control Methods possess the ability to manage the non-linear behavior of complex control structures since they take advantage of heuristics and expert knowledge of the process under control. It is also insensitive to variations in system parameters. However, the strategy is relatively slow. In [24], reference is made to a Fuzzy Logic Controller (FLC) used in the non-linear DG interface for voltage regulation, control of real and reactive power as well as an Adaptive Linear Neuron (ADALINE) utilized to eliminate harmonics and unbalance compensation. The FLC is also implemented together with the conventional Proportional-Integral (PI) controller to regulate voltage and frequency in AC microgrid. In addition, a new intelligent droop control deploying adaptive neuro-fuzzy inference system (ANFIS) is discussed in [24]. This is used to

provide a solution for intelligent model-free based generalized droop control (GDC) and achieves desired voltage and frequency regulation in an islanded microgrid.

#### E. Tools For Optimization of Microgrid Systems

Several software tools have been developed to aid in design, optimization and performance evaluation of microgrid systems [5], [25]-[27]. In [5], a detailed coverage of the software tools for optimization of system with predefined configurations is presented. The software tools include: SOMES, HOMER, HYBRID 2, INSEL, SOLSIM, WATSUN-PV, PVSYS, PV-DESIGN PRO, RAPSIM, PHOTO, RAPSYS, RETScreen and ARES. From these, only the first two (SOMES and HOMER) are recommended for PV-wind hybrid system since both have the ability to provide optimal design of the hybrid system. For instance, HOMER can be used to model both conventional and renewable energy technologies: including PV, wind turbine, diesel generator, fuel cell, utility grid, micro turbine, battery bank and hydrogen storage. It conducts simulation for all of the possible system configurations, including whether off-grid or on-grid and determines a feasible one. Next, HOMER estimates the installation and operation cost of the system and displays a list of configurations arranged according to their life cycle cost [5], [7].

In [25], the Grid IQ Microgrid Control System (MCS) developed by General Electric (GE) is presented. This is a commercial supervisory control architecture based on U90<sup>PLUS</sup> Generation Optimizer that provides optimization solution for permanently islanded or grid-connected microgrids. The software is capable of forecasting load, renewables and electricity price; carry out microgrid generator unit commitment integration, energy storage integration, intelligent local controllers as well a suite of security features.

In [26] the "Microgrid Plus" control system based on MGC600 series of controllers, developed by ABB Australia Pty. Ltd is introduced. This is a commercial modular and networked power flow and energy storage control system which is suitable for stable integration of intermittent renewable generation (e.g. PV and wind) into microgrids. The system is designed for use in isolated microgrids such as in remote communities as well as in predominantly grid-connected microgrids such as for industrial complexes.

In [27], the state of commercial microgrid controllers is captured, exposing the strengths and weaknesses of adopting such microgrid control strategies. Currently, most suppliers offer a microgrid control solution instead of a set of microgrid control products that can be accessed off-the-shelf and utilized directly in a project by the system owner's engineers. This denies the system investors some level of flexibility, scalability and accessibility in implementing controls. In addition, although the proprietary approaches offer a high level of security and reliability, there are challenges regarding the long-run sustainability and maintainability of the proprietary aspects of the control system. Any change in the microgrid system characteristics raises maintenance costs due to continued vendor involvement. For example, there may be a need to incorporate a new generation unit such as a PV system or wind turbine or load (due to increased demand) or a new component (due to technological changes). This hinders scalability to the microgrid system.

#### F. Other Control Strategies and Emerging Issues

ANFIS based Generalized Droop Control (GDC) is referred to in [28]. It is used to overcome the drawbacks of GDC-based frequency and voltage control in microgrids utilizing more than one DG (e.g. PV and WT). The ANFIS-based GDC deploys the training ability of the ANN to the FL to create a new hybrid technique, termed ANFIS and is trained using input-output (I/O) data saved from the GDC approach. This strategy is applicable to a wide range of MGs and does not require knowledge about the MG structure as well as the line parameters [28].

Microgrid islanding control can be achieved through the peer-to-peer strategy or master-slave strategy [29]. The peer-to-peer strategy allows for plug-and-play feature which means that microsources may be added to the microgrid without any adjustments to the existing control and protection set up. This may be implemented using droop control. In the master-slave strategy, there is a master controller while the others are slave controllers which receive instructions from the master controller via a communication link. In islanded mode, the master controller in the microgrid maintains the system frequency, and also power balance separately using suitable algorithm. The future research direction is suggested to focus on improving the operation, control and optimization of different DG systems including renewable intermittent (PV or WT), controllable, conventional and converter mode DG [29].

### IV. MICROGRID CHALLENGES AND PROPOSED CONTROL FRAMEWORK

#### A. Microgrid Challenges

The development and utilization of microgrid systems (hybrid or otherwise) cannot be undertaken without technical, design, integration, protection, social, policy and sustainability challenges [1], [4], [28], [30]-[33]. In general, the generic challenges of a microgrid system have a huge stake in hybrid microgrid systems too. In [28], the technical challenges facing microgrid are summarized. Some of the technical challenges regarding hybrid microgrids include [4] and [28]:

- a) Unstable operation when faults and various disturbances occur in the absence of storage elements.
- b) Sophisticated control strategies are required to ensure stability and power quality especially in the islanded mode of operation.
- c) Lack of seamless transitions from grid-connected to isolated mode of operation may lead to large mismatches between generation and load. This presents serious challenge to voltage and frequency control.
- d) Difficulties in coordinated control in situations involving a large number of intermittent microsources.
- e) Limitations in communication lead to adoption of distributed intelligent strategies.
- f) In low voltage networks, the resistance to reactance ratio is high, which challenges decoupled and independent control of active power, P and reactive power, Q.

The challenges of microgrids in remote communities is presented in [30]. Here, the STEEP model, which stands for social (S), technical (T), economic (E), environmental (E) and

policy (P) is proposed and used to identify, classify and achieve sustainable microgrids. The microgrid failure factors, sustainable microgrid factors and sustainable planning network are presented in detail. The issues regarding the modeling and simulation of hybrid microgrid systems are given in [31]. Most important in hybrid microgrids is the challenge of establishing the operation modes or regimes for the entire energy conversion system. Also, is the linearization of the mathematical model in the electrical machine modeling of wind energy system to reduce their order. The challenges associated with integration of Renewable Energy Resources, recognizing that solar and wind power are intermittent and non-dispatchable, are detailed in [32]. These include high variability of wind power, changes in wind generator frequency, time lag between solar generation peak and late afternoon demand peak, rapid solar output variation due to passing clouds, power quality reduction and limited forecasting abilities. Finally, challenges regarding design of microgrid protection systems are highlighted in [1] and [4]. They are due to: bidirectional power flow, network topology change (mesh or ring network), and converter interfacing (due to extremely low inertia of interfaced inverters).

#### B. Proposed Control Framework

From the literature reviewed, it is clear that every control strategy has its merits and demerits. Consequently, every approach should be assessed based on the needs of a microgrid set up for which it was designed. The first step in choosing a control strategy is to determine whether the microgrid will be grid connected or islanded or making transitions between the two. If on-grid, the microgrid control strategy is determined by the utility whereas in islanded mode of operation, the control strategy is determined by a set of factors. These include type of microsources and net capacity, capacity of available energy storage, type of load and ownership.

Based on shortcomings of existing microgrid control methods and considering the above factors, the strategy proposed in this study for control of a microgrid with PV-wind hybrid generation systems is a scalable Multilevel Microgrid Control System (MMCS) shown in Fig. 9. This should use MPC-ANFIS controller supported with either PSO or GA. The PSO or GA should be used to obtain optimal size of PV and wind turbines of the hybrid microgrid system based on the available meteorological data. The MPC should be used to modify the PQ or droop control method and the input output (I/O) data acquired used to train the ANFIS. The performance of the proposed strategy should be tested on a feasible case study.

### V. CONCLUSION AND DIRECTIONS OF FUTURE RESEARCH

This study reviewed the advances made towards the utilization of microgrid systems with PV-Wind generation units with emphasis on the applicable microgrid control systems, strategies and principles. Based on the review conducted, it was noted that every control strategy has its merits and demerits as well as levels of efficiency and cost particularly if extended to different microgrid scenario. As a result of this, a Multilevel Microgrid Control System (MMCS) incorporating suitable artificial intelligence algorithms has been suggested as a viable solution to the control challenges of PV-Wind hybrid

generation microgrid system. The directions taken by research in this field include using artificial intelligence and other nature-inspired algorithms to optimize performance of a hybrid microgrid system. Further, the decentralized hierarchical control is increasingly becoming common.

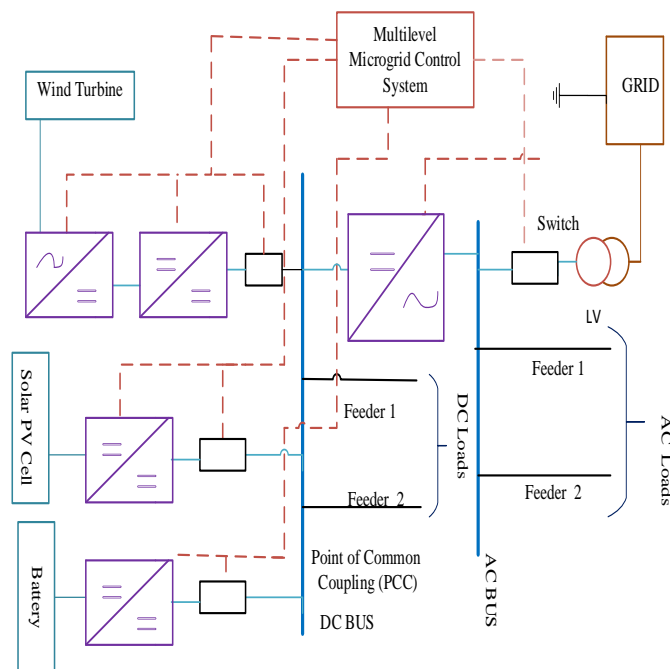

Fig.9 Proposed Microgrid Control System Layout

#### REFERENCES

- [1] M. A. Aminu and K. Solomon, "A Review of Control Strategies for Microgrids," *Advances in Research, SCIENCE DOMAIN international*, Article no. AIR.25722-ISSN: 2348-0394, 2016.
- [2] A. Bidram, V. Nasirian, A. Davoudi and F. L. Lewis, "Cooperative Synchronization in Distributed Microgrid Control", *Advances in Industrial Control*, Springer International Publishing AG, XVI, pp. 242, 2017.
- [3] M. N. Ahmed, M. Hojabri, A.M. Humada, H. B. Daniyal and H.F. Frayeh, "An Overview on Microgrid Control Strategies," *International Journal of Engineering and Advanced Technology (IJEAT) ISSN: 2249 – 8958, Volume-4 Issue-5, June 2015.*
- [4] D. E. Olivares, C. A. Cañizares, and M. Kazerani, "Trends in Microgrid Control," *IEEE Transactions on Smart Grid*, Vol. 5, No. 4, 2014.
- [5] Y. Sawle1, S.C. Gupta1 and A. K. Bohre, "PV-wind hybrid system: A review with case study," *Cogent Engineering*, 2016.
- [6] Y. Shen, "Microgrid Control Strategy Study and Controller Design Based On Model Predictive Control," *Master of Science Thesis, University of Denver*, March 2017.
- [7] R. A. Badwawi1, M. Abusara1 and T. Mallick, "A Review of Hybrid Solar PV and Wind Energy System," *Smart Science*, Vol. 3, No. 3, pp. 127-138, April 2015.
- [8] O. Palizban and K. Kauhaniemi, "Microgrid Control Principles in Island Mode Operation," carried out in *Smart Grids and Energy Markets (SGEM)*, IEEE Conference Paper, 2013.
- [9] P. Borazjani, N.I.A. Wahab, H. B. Hizam and A. Bt Che Soh, "A Review on Microgrid Control Techniques," *IEEE Innovative Smart Grid Technologies - Asia (ISGT ASIA)*, 2014.
- [10] K. A. Jada, H. M. Karkar and I. N. Trivedi, "A Review of Microgrid Architectures and Control Strategy," Springer, *The Institution of Engineers (India)*, 2017.
- [11] Z. Chen, K. Wang, Z. Li and T. Zheng, "A Review on Control Strategies of AC/DC Micro Grid," *IEEE*, 2018.
- [12] D. Ton, "Microgrid Controls and Management Systems," *Power Systems Engineering Research and Development, Office of Electricity Delivery & Energy Reliability, USA*, July 2015.

- [13] M. A. Hossain, H. R. Pota, W. Issa and M. J. Hossain, "Overview of AC Microgrid Controls with Inverter-Interfaced Generations," *Energies Article*, 10, 1300, 2017. Available at [www.mdpi.com/journal/energies](http://www.mdpi.com/journal/energies). [Accessed: 28/3/2018].
- [14] L. Meng, Q. Shafiee, G. F. Trecate, H. Karimi, D. Fulwani, X. Lu and J.M. Guerrero, "Review on Control of DC Microgrids and Multiple Microgrid Clusters," *IEEE Journal of Emerging and Selected Topics In Power Electronics*, Vol. 5, No. 3, September 2017.
- [15] T.M. Reshma and J. Deepu, "Droop Control Method for Parallel DC Converters used in Standalone PV-Wind Power Generating System," *International Journal of Research in Engineering and Technology*, Vol. 4 Issue 10, pp. 297-302, October 2015.
- [16] Y. LI and F. NEJABATKHAH, "Overview of control, integration and energy management of microgrids," *Springer, J. Mod. Power Syst. Clean Energy*, 2(3):212–222, August 2014.
- [17] L. I. Minchala-Avila, L. E. Garza-Castañón, A. V. Martinez, and Y. Zhang, "A review of optimal control techniques applied to the energy management and control of microgrids," *Elsevier-ScienceDirect, Procedia Computer Science* issue 52, pp. 780 – 787, 2015.
- [18] U.S. Department of Energy (DOE), "Enabling Modernization of the Electric Power System," *Quadrennial Technology Review: An Assessment of Energy Technologies and Research Opportunities*, Chapter 3, September 2015.
- [19] T. Morstyn, B. Hredzak, R.P. Aguilera and V. G. Agelidis, "Model Predictive Control for Distributed Microgrid Battery Energy Storage Systems," *IEEE*, February 2017.
- [20] Y. DU, W. PEI, N. CHEN, X. GE and H. XIAO, "Real-time microgrid economic dispatch based on model predictive control strategy," *Springer, J. Mod. Power Syst. Clean Energy*, 5(5), pp. 787–796, February 2017.
- [21] T. Wang, X. He and T. Deng, "Neural networks for power management optimal strategy in hybrid microgrid," *The Natural Computing Applications Forum 2017*, Springer, 2017.
- [22] N. Borges, J. Soares and Z. Vale, "A Robust Optimization for Day-ahead Microgrid Dispatch Considering Uncertainties," *Elsevier-ScienceDirect, IFAC PapersOnline* 50-1, 3350-3355, 2017.
- [23] M. Jayachandran and G. Ravi, "Design and Optimization of Hybrid Micro-Grid System," *Elsevier-ScienceDirect, Energy Procedia*, 117, pp. 95–103, 2017.
- [24] V. Lavanya and N. S. Kumar, "A Review: Control Strategies for Power Quality Improvement in Microgrid," *INTERNATIONAL JOURNAL of RENEWABLE ENERGY RESEARCH*, Vol.8, No.1, March, 2018.
- [25] GE Digital Energy, "Grid IQ™ Microgrid Control System: Optimization Solution for Permanently Isolated or Grid-Connected Microgrids," 2012, Available at [GEDigitalEnergy.com](http://GEDigitalEnergy.com). [Accessed: 30/3/2018].
- [26] M. Jansen, "Microgrid Plus-A networked, easy to apply power flow control system for stable integration of intermittent renewable generation into microgrids," *ABB Australia Pty. Ltd*, Available at [www.abb.com](http://www.abb.com) [Accessed: 1/4/2018].
- [27] F. Katiraei, A. Zamani, and R. Masiello, "Microgrid Control Systems: A Practical Framework," *IEEE Power & Energy Magazine*, pp.110-116, 2017.
- [28] R. Jain and A. Arya, "A Comprehensive Review on Micro Grid Operation, Challenges and Control Strategies," *ACM*. ISBN 978-1-4503-3609-3/15/07, 2015.
- [29] W. Huang, M. Lu and L. Zhang, "Survey on Microgrid Control Strategies," *Elsevier-ScienceDirect, Energy Procedia*, 12, pp. 27–30, September 2011.
- [30] D. Akinyele, J. Belikov and Y. Levron, "Challenges of Microgrids in Remote Communities: A STEEP Model Application," *Energies-MDPI Article*, 11, 432, February 2018.
- [31] I Szeidert, I. Filip and O. Prosteas, "Issues regarding the modelling and simulation of hybrid micro grid systems," *IOP Conf. Series: Materials Science and Engineering* 106 012028, 2016.
- [32] K. Patel and S. Singh, "An Overview of DC-Microgrid Architecture with Renewable Energy Resources," *International Journal of Advance Engineering and Research Development (IAERD)*, 2015.