

**The Anti-malarial and Biochemical Studies of *Microglossa pyrifolia*  
(Lam.) Ktze and *Trimeria grandifolia* (Hochst.) Warb from Lake  
Victoria Basin, Kenya**

**Charles Onyango Omollo**

**A thesis submitted in partial fulfillment for the Degree of Master of Science in  
Medicinal Chemistry in the Jomo Kenyatta University of Agriculture and Technology**

**2011**

## DECLARATION

This thesis is my original work and has not been presented for a degree in any other University.

Signature..... Date.....

**Charles Onyango Omollo**

This thesis has been submitted with our approval as University Supervisors.

1. Signature..... Date.....

**Prof. Joseph M. Keriko**

**JKUAT, Kenya**

2. Signature..... Date.....

**Dr. Geoffrey Rukunga**

**KEMRI, Kenya**

## **DEDICATION**

This thesis is dedicated to my wife Rose, sons Wayne and Curtis who patiently waited for me to log off.

## ACKNOWLEDGEMENT

All thanks to the Almighty God who is the source of my strength and the reason for my living. I am greatly indebted to my supervisors Prof. Joseph M. Keriko and Dr. Geoffrey Rukunga for their guidance and support in ensuring that this work became a success. Many thanks to Prof. Isaiah O. Ndiege who contributed in running NMR spectra and offered advise from time to time. I appreciate Prof. Teresa Akeng'a for advising me on this project and making available certain chemicals and reagents for this work.

Sincere thanks to Centre for Traditional Medicine and Drug Research (CTMDR) staff at KEMRI; especially Dr. C. Mutai and Miss. E. Kigonde for their immense contributions on fractionation and structure elucidation, Mr. J. Waweru, Ms. B. Irungu, Mr. N. Mwikabe for their help on *in vitro* work and Mr. C. Muthaura who assisted with availing laboratory apparatus. Others including Dr. J. Orwa, Dr. C. Mutai, Dr. F. Tolo, Dr. E. Matu, Dr. L. Keter, Mr. P. Kirira, Mr. P. Mwitari, Ms. J. Odachi, Ms. L. Ngeny, Ms. C. Wanjiku, Ms. M. Muthoni, Mr. S. Mwangi, Mr. D. Odira , Ms. G. Wambui, Mr. I. Munene, Mr. D. Karogo, Mr. G. Kibindu and Mr. K. Murega from whom I benefited in one way or the other. I am grateful to KEMRI administration through Dr. G. Rukunga who allowed me to use their facilities at CTMDR.

I appreciate the technical assistance given by Ms. E. Waithera (Chemistry Dept. JKUAT) in obtaining IR spectra. Finally, I wish to salute my family Rose, Wayne and Curtis from whose encouragement enabled me to press on to the completion of this work.

## TABLE OF CONTENTS

Page

<b>DECLARATION.....</b>	<b>i</b>
<b>DEDICATION.....</b>	<b>ii</b>
<b>ACKNOWLEDGEMENT.....</b>	<b>iii</b>
<b>TABLE OF CONTENTS.....</b>	<b>v</b>
<b>LIST OF TABLES.....</b>	<b>xi</b>
<b>LIST OF SCHEMES.....</b>	<b>xii</b>
<b>LIST OF APPENDICES.....</b>	<b>xiii</b>
<b>LIST OF ABBREVIATIONS.....</b>	<b>xv</b>
<b>ABSTRACT.....</b>	<b>xvii</b>
<b>CHAPTER 1.....</b>	<b>1</b>
<b>1.0 INTRODUCTION .....</b>	<b>1</b>
1.1 Malaria.....	1
1.2 Malaria Epidemiology .....	1
1.3 Vaccine Development .....	3
1.4 Malaria Chemotherapy .....	6
1.5 Natural Products in Drug Discovery .....	6
1.6 Natural Products as Anti-malarial Drugs.....	8

<b>CHAPTER 2</b> .....	<b>10</b>
<b>2.0 LITERATURE REVIEW</b> .....	<b>10</b>
2.1 Single Drug Therapies .....	10
2.2 Combination Therapy with Anti-malarial Drugs .....	15
2.3 Anti-malarial Compounds from Nature.....	16
2.3.1 Alkaloids .....	17
2.3.1.1 Quinoline Alkaloids.....	17
2.4 Anti-malarial Plants in this Study .....	30
2.4.1 <i>Microglossa pyrifolia</i> (Lam) Ktze (Astereceae) .....	30
2.4.2 <i>Trimeria grandifolia</i> (Hochst.) Warb (Flacourticeae) .....	33
2.5 Justification.....	334
2.6 Null Hypothesis.....	33
2.7 Objectives .....	36
2.7.1 General Objective.....	36
2.7.2 Specific Objectives.....	36
<b>CHAPTER 3</b> .....	<b>37</b>
<b>3.0 MATERIALS AND METHODS</b> .....	<b>37</b>
3.1 Materials, Reagents and Equipment.....	37
3.1.1 Reagents.....	37
3.1.2 Equipment.....	37

3.1.3 Disposable plastics and glassware.....	38
3.1.4 Recycled glassware .....	38
3.1.5 Sterilizing materials.....	38
3.2 Plant Materials .....	39
3.2.1 Sampling .....	39
3.2.2 Extraction.....	39
3.3.1 Cytotoxicity Assay.....	39
3.3.2 <i>In-vitro</i> Anti-plasmodial assay .....	41
3.3.2.1 Parasites .....	41
3.3.2.2 Parasite Cultivation.....	41
3.3.2.3 Culture Preparations .....	41
3.3.2.3.1 RPMI 1640/ HEPES medium.....	41
3.3.2.3.2 Wash Medium (WM) .....	41
3.3.2.3.3 Uninfected Erythrocyte.....	42
3.3.2.3.4 Preparation of Human Serum.....	42
3.3.2.3.5 Complete culture medium with serum (CMS) .....	43
3.3.2.3.6 Thawing of malaria parasites .....	43
3.3.2.3.7 Setting of the culture.....	44
3.3.2.3.8 Determination of parasitaemia and parasite growth rates.....	44
3.3.2.3.9 Freezing of parasites (cryopreservation).....	45
3.3.2.4 <i>In vitro</i> drug sensitivity test.....	45



3.3.2.4.1 Preparation of plant extracts and chloroquine for <i>in vitro</i> bioassays.....	46
3.3.2.4.2 Preparation of micro-titre plates.....	47
3.3.2.4.3 Addition of parasites to the pre-dosed plates .....	48
3.3.2.4.4 Incubation of the plates.....	50
3.3.2.4.5 Harvesting of cells and scintillation counting .....	51
3.3.2.4.6 Inhibitory concentration (IC <sub>50</sub> ).....	51
3.3.3 Drug combination bioassay.....	52
3.3.3.1 Drug interaction experiments of plant extracts and with chloroquine.....	52
3.4 Fractionation, Purification and Identification .....	53
3.4.1 Chromatography.....	54
3.4.2 Melting point.....	54
3.4.3 Spectroscopy .....	54
3.5 Isolation of compounds from leaves of <i>Trimeria grandifolia</i> (Flacourtiaceae).....	55
3.5.1 Methanol Extract.....	55
3.5.1.1 Acid hydrolysis of TGC 2 .....	56
3.5.2 Dichloromethane Extract .....	57
3.6 Isolation of compounds from <i>Microglossa pyrifolia</i> (Astereceae) leaves.....	59
3.6.1 Chloroform Extract.....	59
3.6.2 Methanol Extract.....	60

<b>CHAPTER 4.....</b>	<b>62</b>
<b>4.0 RESULTS AND DISCUSSIONS.....</b>	<b>62</b>
4.1 Extraction.....	62
4.2 Bioassays .....	63
4.2.1 Cytotoxicity Tests.....	63
4.2.2 Anti-plasmodial Screening of Crude extracts .....	64
4.2.3 <i>In vitro</i> anti-plasmodial screening of pure and impure compounds .....	66
4.2.4 <i>In vitro</i> drug interaction studies.....	67
4.3 Structure elucidation.....	68
4.3.1 Compounds isolated from <i>T. grandifolia</i> .....	68
4.3.1.1 Idesin [6-hydroxy-2-(hydroxymethyl)phenyl β-D-glucopyranoside] TGC2 (61)...	68
4.3.1.1.1 Acid hydrolysis of TGC 2 .....	70
4.3.1.2 Lupenone [Lup-20(29)-en-3-one] TG 4 (62) .....	70
4.3.1.3 β – Sitosterol [3 $\alpha$ -stigman-5-en-3-ol] TGP 33 (63).....	73
4.3.1.3.1 Liebermann – Burchard test on TGP 33 .....	74
4.3.1.4 Friedelanol MP 24 (64).....	75
<b>CHAPTER 5.....</b>	<b>76</b>
<b>CONCLUSION AND RECCOMENDATIONS .....</b>	<b>76</b>
5.1 Conclusion.....	76
5.2 Reccomendations.....	78

**REFERENCES.....76**

**APPENDICES.....94**

### **LIST OF TABLES**

**Table 1:** The yield % of dried extracts of *M. pyrifolia* and *T. grandifolia* leaves...62

**Table 2:** Cytotoxicity (CC<sub>50</sub>) of crude extracts for *T. grandifolia* and

	<i>M. pyrifolia</i> .....	63
<b>Table 3:</b>	<i>In vitro</i> anti-plasmodial activity (IC <sub>50</sub> ) of crude extracts on two <i>P. falciparum</i> .....	65
<b>Table 4:</b>	<i>In vitro</i> anti-plasmodial activity (IC <sub>50</sub> ) of pure and semi-pure compounds <i>M. pyrifolia</i> and <i>T. grandifolia</i> against <i>P. falciparum</i> (W2 & D6). .....	66
<b>Table 5:</b>	Interaction of TGC 2 with chloroquine .....	67
<b>Table 6:</b>	NMR (field, MeOD) data for Idesin [6-hydroxy-2-(hydroxymethyl)phenyl β-D-glucopyranoside] TGC2 (61). .....	69
<b>Table 7:</b>	Comparison of <sup>13</sup> C NMR spectral data for compounds TG 4 and lupenone. ....	71
<b>Table 8:</b>	<sup>13</sup> C NMR (50 MHz) data for β-sitosterol [3β-stigman-5-en-3-ol] TGP 33 (63) in CDCl <sub>3</sub> .....	74
<b>Table 9:</b>	<sup>13</sup> C NMR (50 MHz) data for Friedelanol MP 24 (64) in CDCl <sub>3</sub> .....	75

## LIST OF SCHEMES

<b>Scheme 1:</b>	Isolation of compounds from the methanol extract of <i>T. grandifolia</i> leaves. ....	56
------------------	----------------------------------------------------------------------------------------	----

<b>Scheme 2:</b>	Isolation of compounds from the dichloromethane extract of <i>T. grandifolia</i> .....	58
<b>Scheme 3:</b>	Isolation of compounds from the chloroform extract of <i>M. pyrifolia</i> leaves .....	60
<b>Scheme 4:</b>	Isolation of compounds from the methanol extract of <i>M. pyrifolia</i> leaves .....	61

#### LIST OF APPENDICES

<b>Appendix 1:</b>	IR spectrum of Idesin [6-hydro-2-(hydroxymethyl)phenyl $\beta$ -D glucopyranoside] ( <b>61</b> ).....	94
<b>Appendix 2:</b>	$^1\text{H}$ NMR spectrum of Idesin [6-hydro-2-(hydroxymethyl)phenyl $\beta$ -D-glucopyranoside] ( <b>61</b> ) .....	95

<b>Appendix 3:</b>	<sup>13</sup> C NMR spectrum of Idesin [6-hydro-2-(hydroxymethyl)phenyl β-D-glucopyranoside] ( <b>61</b> ) .....	96
<b>Appendix 4:</b>	DEPT NMR spectrum of Idesin [6-hydro-2-(hydroxymethyl)phenyl β-D-glucopyranoside] ( <b>61</b> ) .....	97
<b>Appendix 5:</b>	HMQC NMR spectrum of Idesin [6-hydro-2-(hydroxymethyl)phenyl β-D-glucopyranoside] ( <b>61</b> ) .....	98
<b>Appendix 6:</b>	IR spectrum of Lupenone [Lup-20(29)-en-3-one] TG 4 ( <b>62</b> ) .....	99
<b>Appendix 7:</b>	<sup>1</sup> H-NMR spectrum of Lupenone [Lup-20(29)-en-3-one] TG 4 ( <b>62</b> )	100
<b>Appendix 8:</b>	<sup>13</sup> C-NMR spectrum of Lupenone [Lup-20(29)-en-3-one] TG 4 ( <b>62</b> )	101
<b>Appendix 9:</b>	IR spectrum of β-sitosterol [3α-stigman-5-en-3-ol] TGP 33 ( <b>63</b> )...	102
<b>Appendix 10:</b>	<sup>1</sup> H-NMR spectrum of β-sitosterol [3β-stigman-5-en-3-ol] TGP 33 ( <b>63</b> ) .....	103
<b>Appendix 11:</b>	<sup>13</sup> C-NMR spectrum of β-sitosterol [3β-stigman-5-en-3-ol] TGP 33 ( <b>63</b> ) .....	104
<b>Appendix 12:</b>	DEPT spectrum of β-sitosterol [3β-stigman-5-en-3-ol] TGP 33 ( <b>63</b> )	105
<b>Appendix 13:</b>	HMQC spectrum of β-sitosterol [3β-stigman-5-en-3-ol] TGP 33 ( <b>63</b> ) .....	106
<b>Appendix 14:</b>	IR spectrum of friedelanol MP 24 ( <b>64</b> ) .....	107
<b>Appendix 15:</b>	<sup>1</sup> H-NMR spectrum of friedelanol MP 24 ( <b>64</b> ) .....	108
<b>Appendix 16:</b>	<sup>13</sup> C-NMR spectrum of friedelanol MP 24 ( <b>64</b> ) .....	109

<b>Appendix 17:</b>	DEPT spectrum of friedelanol MP 24 ( <b>64</b> ).....	110
<b>Appendix 18:</b>	HMQC spectrum of friedelanol MP 24 ( <b>64</b> ).....	112

#### **LIST OF ABBREVIATIONS**

<b>CC</b>	Column Chromatography
<b>CC<sub>50</sub></b>	Cytotoxicity on 50 % of cells
<b>CMS</b>	Complete Medium Culture in Serum
<b>CQ</b>	Choloroquine

<b>DEPT</b>	Distortionless Enhancement by Polarisation Transfer
<b>DMSO</b>	Dimeyhylsulphoxide
<b>DNA</b>	Deoxyribonucleic acid
<b>EtOAc</b>	Ethyl acetate
<b>FBS</b>	Fetal Bovine Serum
<b>FIC</b>	Fraction Inhibition Concentration
<b>HEPES</b>	N-2-hydroxyethylpiperazine-N-2-ethanesulfonic acid
<b>HETCOR</b>	Heteronuclear Correlation Spectroscopy
<b>HMQC</b>	Heteronuclear Multiple Quantum Correlation
<b>IR</b>	Infra red
<b>MeOH</b>	Methanol
<b>MEM</b>	Minimum Essential Medium
<b>MTT</b>	3-(4,5-dimethylthiazol-2-yl)-2,5-diphenyltetrazoliumbromide
<b>NMR</b>	Nuclear Magnetic Resonance
<b>PTLC</b>	Preparative Thin Layer Chromatography
<b>PRBC</b>	Parasitized Red Blood Cells
<b>RBC</b>	Red Blood Cells
<b>RPMI</b>	Rosewell Park Memorial Institute
<b>R<sub>f</sub></b>	Retention factor
<b>TDR</b>	Tropical Diseases Research
<b>TLC</b>	Thin Layer Chromatography



<b>URBC</b>	Unparasitized Red Blood Cells
<b>UV</b>	Ultra Violet
<b>WHO</b>	World Health Organization
<b>WM</b>	Wash Medium
<b><sup>13</sup>C NMR</b>	Carbon 13 Nuclear Magnetic Resonance
<b><sup>1</sup>H NMR</b>	Proton Nuclear Magnetic Resonance

## ABSTRACT

Malaria continues to kill over a million people each year, with more than 90% of these cases found in sub-Saharan Africa. In this work, two plants used as traditional medicine in the Lake Victoria basin; *Microglossa pyrifolia* (Lam.) Ktze. (compositae) and *Trimeria grandifolia* (Hochst.) Warb. (Flacourtiaceae), were investigated for their anti-plasmodial and biochemical principles. On the anti-plasmodial assay, aerial parts of *M. pyrifolia* methanol extract had the highest anti-plasmodial activity against *P. falciparum* chloroquine sensitive, D6 strain ( $IC_{50} 1.59 \pm 0.07 \mu\text{g/ml}$ ) and chloroquine resistant, W2 strain ( $2.50 \pm 0.15 \mu\text{g/ml}$ ) strains. Similarly, the methanol extract of *T. grandifolia* showed activity ( $IC_{50} 17.16 \pm 0.03 \mu\text{g/ml}$ ) and ( $IC_{50} 19.21 \pm 2.18 \mu\text{g/ml}$ ) on D6 and W2 strains. All extracts subjected to cytotoxicity assay did not show any cytotoxic effect on Vero 199 cells ( $CC_{50} > 20 \mu\text{g/ml}$ ). Extracts of *M. pyrifolia* and *T. grandifolia* were subjected to bioassay-guided fractionation. Pure and semi-pure compounds obtained were also subjected to anti-plasmodial assay. Compound TGC 2 had activity on both D6 ( $IC_{50} 9.78 \pm 3.2 \mu\text{g/ml}$ ) and W2 ( $14.4 \pm 1.35 \mu\text{g/ml}$ ) strains. Compound MPC 3 also showed activity on CQ sensitive D6 strain ( $IC_{50} 11.12 \pm 2.31 \mu\text{g/ml}$ ). MPC 2 had a higher activity on CQ resistant strain W2 ( $IC_{50} 24.22 \pm 2.51 \mu\text{g/ml}$ ) compared to CQ sensitive strain D6 ( $IC_{50} 27.11 \pm 1.18 \mu\text{g/ml}$ ) although both activities were generally low according to KEMRI criteria. An interaction study was carried out using compound TGC 2 and chloroquine diphosphate. An additive interaction effect was observed with Fraction Inhibition Concentration [sum FIC ( $\geq 1 - <2$ )] Structure elucidation of *T. grandifolia* showed three compounds Idesin [6-hydroxy-2-(hydroxymethyl)phenyl  $\beta$ -D-glucopyranoside] TGC2 (**61**) of which is reported here for the first time, Lupenone [Lup-20(29)-en-3-one] TG 4 (**62**) and  $\beta$ - sitosterol [TGP 33 (**63**)] and one compound Friedelanol [MP24 (**64**)] from *Microglossa pyrifolia*.

## **CHAPTER 1**

### **1.0 INTRODUCTION**

#### **1.1 Malaria**

Parasitic infections are still one of the major causes of mortality in the third world countries. Parasitic protozoan belonging to genus *Plasmodium* causes malaria, which is one of the most severe tropical diseases. The four identified species of the parasite responsible for inflicting human malaria are *Plasmodium falciparum*, *P. vivax*, *P. ovale*, and *P. malariae*. Of these, *P. falciparum* and *P. vivax* account for more than 95% of malaria cases in the world. Malaria infections caused by *P. falciparum* are prevalent in the major parts of Sub-Saharan Africa and East Asian countries, whereas *P. vivax* is the causative species primarily of Indian sub-Continent (Campbell, 1997). The disease can be treated in just 48 hr., yet it can cause fatal complications if the diagnosis and treatment are delayed. The tropical regions provide ideal breeding and living conditions for the anopheles mosquito (Vangapandu *et al.*, 2006).

#### **1.2 Malaria Epidemiology**

Malaria remains one of the worlds' health problems. It exacts an enormous human and socio-economic toll in more than 90 countries, with estimated numbers of 300 - 500 million clinical cases and 1.5 - 2.7 million deaths per year (WHO, 1996). It is therefore considered as the World's important parasitic disease (WHO, 1996).

This burden of mortality falls mostly heavily on Sub-Saharan Africa, where more than 90% of these deaths occur of the remaining, 10% is concentrated in Asia and Latin

America in countries such as India, Brazil, Sri Lanka, Afghanistan, Vietnam and Colombia (Carter and Kamini, 2002). A report by WHO experts indicates that the number of people Worldwide infected with malaria is still increasing despite the extensive control programmes by WHO (Dutta, 1995). Mortality and morbidity due to malaria are a matter of great concern throughout the World, especially in the tropical and sub tropical regions. Even though casualty in children below the age of 5 years is very high, the disease affects all age groups (Dev *et al.*, 2001).

Malaria is perceived by many African communities as one of their biggest health challenges (Ongore *et al.*, 1989). It is a classic example of a disease that affects the productivity of individuals, families and the whole society (Sudhanshu *et al.*, 2003). Patients with uncomplicated malaria are incapacitated for an average of 3.5 days (5 days in children) and take up the time of other family members who must look after them. In malaria endemic regions, adults experience up to 2 attacks per year and children up to 7 attacks per year. This amounts to the loss of 21 days of output per case, or 1 % GDP loss in Africa (Wilcox and Gerard, 2004). Besides this expense, additional costs are incurred through available malaria treatment control approaches like chemotherapy and insecticide treated bed nets.

Studies have revealed that these malaria management efforts are likely to affect the natural immunity in hyperendemic areas and cause upsurge in mortality (Shalmiev *et al.*, 1996). In Kenya, malaria is the greatest contributor to rising morbidity and mortality of

all infectious diseases (Malakooti *et al.*, 1998). More than half the population (about 20 million people) is exposed to malaria transmission; this includes 3.5 million children below the age of 5 years. The disease, which has continued to increase in severity and frequency since the 1980s, is endemic in Kenya with the highest incidences being recorded in the Western and Coastal regions, parts of Rift Valley, Central and Eastern Provinces (Snow *et al.*, 1999). Due to the increasing emergence of drug resistant strain, the Kenya Medical Research Institute (KEMRI) advocates for reintroducing DDT, a malaria fighting insecticide that could reduce malaria by 80 per cent ([www.Kmis.org/Default.htm](http://www.Kmis.org/Default.htm), 2002). Resistance to anti-malarials has led to enhanced awareness of the risk of malaria. Lack of affordable effective cure has often resulted in severe malaria cases and deaths. Consequently, the magnitude of malaria can no longer be underestimated. In view of this, the Kenya government has created the National Malaria Control Program to coordinate advocacy and control efforts initiated locally and by wider regional and international organizations like the East Africa Network for Monitoring Anti-malarial Treatment and Global Parasite Control Initiative (<http://eanmat.org/>; [www.tmacipac.mahidol.ac.th/home/gpcci.html](http://www.tmacipac.mahidol.ac.th/home/gpcci.html)).

### **1.3 Vaccine Development**

Malaria vaccine development has faced a number of impediments in the last decades. These include the complex multi-stage life cycle of the malaria parasite, the heterogeneity of immune responses required for protection, interference from potentially disease-enhancing immune responses, a lack of adequate animal models for evaluating vaccine

efficacy, as well as in adequate funding ([www.who.int/vaccines-documents/](http://www.who.int/vaccines-documents/)). Three main approaches to malaria vaccine development based on different stages of Plasmodium life cycle have been targeted. These are the pre erythrocytic stage (when the parasite is in the hepatocytes), the asexual stage (when the parasite binds and infects the erythrocytes) and the sexual stage (involves vaccines that elicits antibodies which prevent the development of the sexual stage within the midgut of the mosquito) (Nussenzweig and Nardin, 1993).

All Plasmodium species have distinct forms in both the human and mosquito stages of their life cycle. The first malaria vaccine was made from fragmented and dissolved malaria parasites, chosen in the form that is ready to invade red blood cells (merozoites). Tested in the 1960s, this vaccine gave some protection in experimental monkey models. But inconsistent results, difficulties in producing immunizing material, and dependence on toxic adjuvant led to a halt of such trials. Instead, workers took an alternative approach using the emergent recombinant DNA/genetic engineering technologies to purify individual protective merozoite surface components that could be recognized by the immune system (antigens) (Arnot, 2005). Other investigators attempted to create vaccines using attenuated sporozoites — the form of the malaria parasite that is transferred to humans by mosquitoes and that invades the liver. Live, infected mosquitoes were used to deliver the vaccine after having first been subjected to X-ray radiation to render the parasites unable to multiply. A very high proportion of volunteers bitten by the irradiated mosquitoes could subsequently fight off infection with normal untreated malaria

sporozoites. This approach was considered technically difficult by many investigators and impossible to scale up (Luke and Hoffman, 2003).

The focus of malaria vaccine research, therefore, switched to vaccines based on one or more immunogenic components of the parasite, subunit vaccine approach. A key problem for subunit vaccine development is how to choose the parasite component (i.e. the protective antigen) to induce immunity. There are three stages of the malaria parasite's life cycle that seem especially vulnerable to the immune system of infected human hosts and are thus prime vaccine targets. They are the, pre-erythrocytic stage, not only the circulating sporozoites transferred by mosquitoes but also those that continue to develop after entry into the liver. Asexual blood stage, the merozoites that emerge from the liver to invade, and subsequently grow in red blood cells. Sexual blood stage (gametocytes), taken up by the blood-feeding mosquito to continue the protozoan life cycle (Arnot, 2005).

Other candidate trial vaccine include RTS/S, a novel pre-erthrocytic malaria vaccine based on the circumsporozoite surface protein (CSP) of *P. falciparum* linked to hepatitis B surface antigen (HBs) and combined with a novel adjuvant system (S/AS2) (Doherty *et al.*, 1999). A randomized trial of the efficacy of RTS,S/AS2 against natural *P. falciparum* infection in semi-immune adult men in Gambia showed efficacy of 71 % during the first 9 weeks of follow-up (Bojang *et al.*, 2001). It is still undergoing trials in several countries, for example, the vaccine gave around 30 per cent protection overall against the first clinical attack of malaria in Mozambican children and reduced the incidence of severe

disease by 58 % (Alonso *et al.*, 2004). However, the development of an effective vaccine appears to be still a distant dream and malaria chemotherapy remains the primary strategy in managing the disease (Hoffman and Miller, 1996).

#### **1.4 Malaria Chemotherapy**

This involves the use of chemical agents to fight the parasites once they are in the body. Chemoprophylaxis is needed to prevent established infection with the disease, but if an individual is already suffering from the disease or if the parasites evade the prophylactic drug then treatment is necessary (Nkunya, 2002). In most cases, anti-malarial drugs are targeted against the asexual erythrocytic stage of the parasite. The parasites degrade haemoglobin in its acidic vacuole producing free heme able to react with molecular oxygen and generate reactive oxygen species as toxic by-products (Francis *et al.*, 1997). The most common pathway for detoxification of heme moieties is polymerization as malaria pigment (Slater *et al.*, 1991; Pagola *et al.*, 2000). Majority of anti-malarial drugs act by disturbing the polymerization (and the detoxification by any other way) of heme, thus killing the parasite with its own metabolic waste (Egan and Marques, 1999).

#### **1.5 Natural Products in Drug Discovery**

For many decades, synthetic chemicals as drugs have been effective in the treatment of most diseases. The pharmaceutical industry has synthesized over 3 million new chemicals in their effort to produce new drugs. Despite their success in developing drugs to treat or cure many diseases, the treatment of certain diseases such as malaria, cancer, AIDS, heart disease and diabetes has not been a complete success due to the complexity of these



diseases (Adou, 2005). The classic paradigm of synthetic drug development breaks down into drug discovery, drug design, preclinical studies, and clinical studies. This results in a drug-development process that is high risk, time consuming, and expensive. The process requires screening an average of 10,000 active compounds to find a single compound that successfully makes its way through validation to drug approval and the marketplace (Schuster, 2001). In comparison, the World Health Organization (WHO) Guidelines for the Assessment of Herbal Medicines are based on the classical guidelines and follow the classical approach to validating quality, safety, and efficacy with the difference that in the latter the starting point is to look at the natural product in humans (WHO, 1991).

Over the centuries, people have been living in close association with the environment and relying on its flora and fauna as a source of food and medicine. As a result, many societies have their own rich plant pharmacopeias. In developing countries, due to economic factors, nearly 80% of the population still depends on the use of plant extracts as a source of medicine (Philipson and Wright, 1991; Adou, 2005). The isolation of the analgesic morphine from the opium poppy, *Papaver somniferum*, in 1816 led to the development of many highly effective pain relievers (Benyhe, 1994). The discovery of penicillin from the filamentous fungus *Penicillium notatum* by Fleming in 1929 had a great impact on the investigation of nature as a source of new bioactive agents (Bennett and Chung, 2001). Natural products can also be used as starting materials for semi-synthetic drugs. The main examples are plant steroids, which led to the manufacture of oral contraceptives and other

steroidal hormones. Today, almost every pharmacological class of drugs contains a natural product or natural product analog.

The investigation of higher plants has led to the discovery of many new drugs. So far only a small portion of higher plants has been investigated. Consequently, they still remain a big reservoir of useful chemical compounds not only as drugs, but also as templates for synthetic analogues (Adou, 2005).

### **1.6 Natural Products as Anti-malarial Drugs**

Traditional medicines have been used to treat malaria for thousands of years and are the source of two main groups (artemisinin and quinine derivatives) of modern anti-malarial drugs (Wilcox and Gerard, 2004). With the problems of increasing resistance, difficulties in poor areas of being able to afford and access effective antimalarial drugs, and difficulty in creating efficient vaccines may imply that traditional medicines becomes an important and sustainable source of treatment ( Wilcox and Gerard, 2004; Grellier *et al.*, 2005).

The Research Initiative on Traditional Antimalarial Methods (RITAM) founded in 1999 aimed on furthering research on traditional medicines for malaria. Their studies showed that more than 1200 plant species from 160 families have been used to treat malaria in about 30 countries (Bodeker and Wilcox, 2000).

Kenyan medicinal plants continue to be used in treatment of malaria and the evaluation of their activity against *P. falciparum* is extensively studied (Kofi-Tsekpo *et al.*, 1989; Gakunju *et al.*, 1995; Oketch-Rabah *et al.*, 2001; Muregi *et al.*, 2003; Muthaura *et al.*, 2007). In a study carried out in Marigat division of Baringo District in Kenya, it was found that in addition to western-based health care, indigenous forms of treatment were being used in the management of malaria (Kaendi, 1994). Various plants are used, alone or in combination for malaria therapy. The plants include: *Mormodica friesiorum* (Cucurbitaceae), *Myrsine africana* (Myrsinaceae), *Azadirichta indica* (Meliaceae), *Warbugia ugandensis* (Canellaceae), *Ajuga remota* (Acanthaceae), *Todallia asiatica* (Rutaceae), among others (Gachathi, 1989; Kokwaro, 1993).

Plants are a potential source of new anti-plasmodial compounds and therefore, the focus of the current anti-malaria drug research and development.

## CHAPTER 2

### 2.0 LITERATURE REVIEW

#### 2.1 Single Drug Therapies

Quinoline containing compounds for example quinine (**1**) have long been used for treatment of malaria (Madrid *et al.*, 2005). Quinine is the main alkaloid from Cinchona bark. It has both a quinoline and quiniclidine ring structure. Quinine is mainly a blood schizonticide with some gametocycidal activity. It is used in falciparum malaria or in mixed infections (Mwagiru, 2005).

Systematic modification of quinine led to the potent and inexpensive 4-aminoquinoline drug chloroquine (**2**) (Foye, 1974).

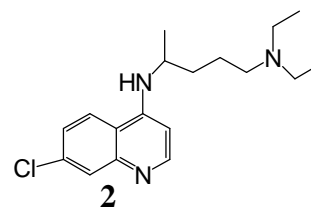
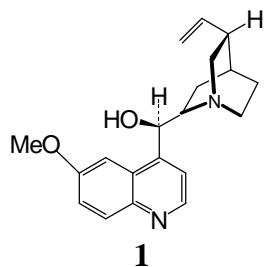

After the Worldwide development of resistance to chloroquine, structure activity studies produced mefloquine (**3**) (WHO, 1984). This is formed by replacing the quiniclidine structure of quinine by a piperidine ring without loss of activity (Mwagiru, 2005). Mefloquine, like quinine is a lipophilic drug that binds tightly to serum component, including high-density lipoproteins (Desnerves *et al.*, 1996). This facilitates the delivery

of mefloquine to the parasite, as plasmodia have been shown to accumulate lipids and other hydrophobic molecules from the serum (Grellier *et al.*, 1991; Berman *et al.*, 1994).

Mefloquine is a blood schizonticide. It is mainly used for prophylaxis of malaria in regions with falciparum malaria risk. It produces a cure in falciparum malaria and suppresses vivax and ovale malaria (Mwagiru, 2005).

Since the development of mefloquine, there have been several reports of other potent quinoline compounds. Amodiaquine (**4**) for example, is still effective on chloroquine resistant strains and is a promising lead for the development of new drugs (Madrid *et al.*, 2005). Amodiaquine is a more active inhibitor than chloroquine of the growth of *P. falciparum in vitro* (Ekweazor *et al.*, 1987). However, amodiaquine is rapidly metabolized *in vivo* to its desethyl derivative that has a significantly reduced activity (Churchhill *et al.*, 1985).

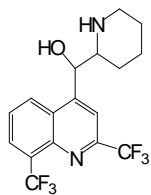

**3**

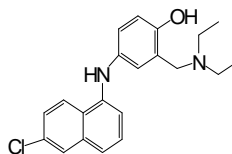

**4**

Other derivatives of quinine include primaquine (**5**), an 8-aminoquinoline with an intact quinoline structure and the side chain altered (Mwagiru, 2005). The drug is effective in clearing erythrocytic stages of malaria parasite (Jain *et al.*, 2004). The main problem

associated with the use of the 8-aminoquinolines is their haemolytic toxicity and the necessity for prolonged administration in radical treatment (Wernsdofer and Trigg, 1984). Quinacrine/mepacrine drugs (**6**) were synthesized because of known antiseptic activity of acridine. They are strong bases because they undergo tautomerism that stabilizes the protonated form (**7**) (Mwagiru, 2005).

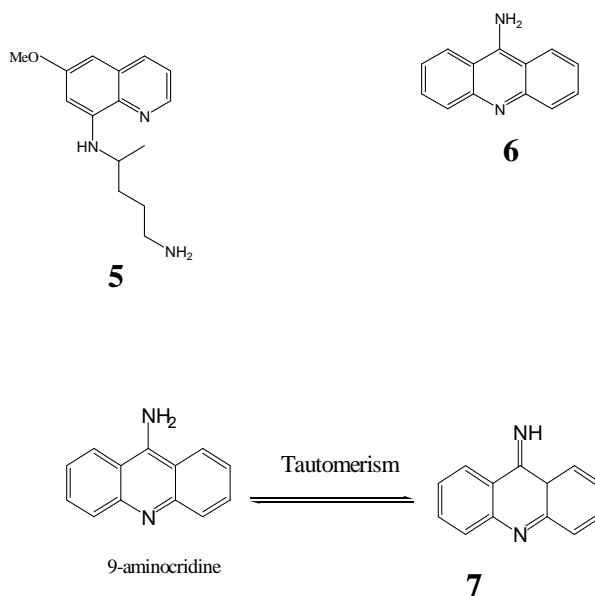

Chlorproguanil (**8**) and dapsone (**9**) belong to a class of anti-malarial drugs known as dihydrofolate reductase (DHFR) inhibitors. This class of drugs works by blocking the synthesis of tetrahydrofolate, which is essential for DNA synthesis in the sexual replication (schizogony) of the blood stages of malarial parasites (Curtis, 2000).

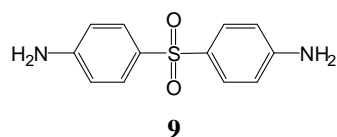
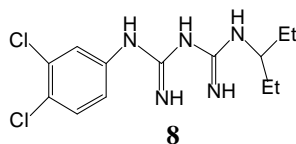

Atovaquone (**10**), a hydroxynaphthoquinone has been used mainly for treatment of opportunistic infections in immuno-suppressed patients. It is effective against chloroquine resistant falciparum malaria, but resistance develops rapidly when used alone (Looaresuwan *et al.*, 1996). Atovaquone is therefore usually given in combination with Proguanil (**11**) (Looaresuwan *et al.*, 1996; Radlof *et al.*, 1996).

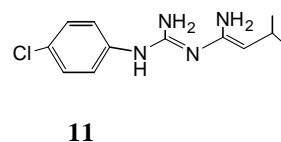
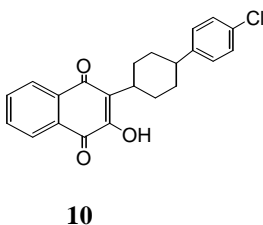

Sulfadoxine (**12**) is an example of a long-acting sulfonamide. Pyrimethamine (**13**) is a dihydrofolate reductase inhibitor. It is mainly used in combination with long-acting sulfonamides such as sulfadoxine. The DHFR inhibitors inhibit the development of mature trophozoite stage of asexual parasite, in addition to having pre-erythrocytic and sporontocidal activities (Wistanley *et al.*, 1992).

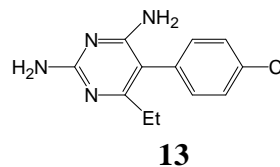
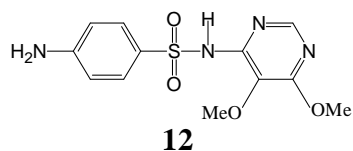

Halofantrine (**14**) belongs to a class of compounds known as phenanthrenemethanol (WHO, 1984). Halofantrine is formed by replacement of the quinoline nucleus with a phenanthrone structure (Mwagiru, 2005). Structurally related to halofantrine is lumefantrine (**15**). This compound has gained importance because it is effective in chloroquine resistant falciparum malaria (Mwagiru, 2005).

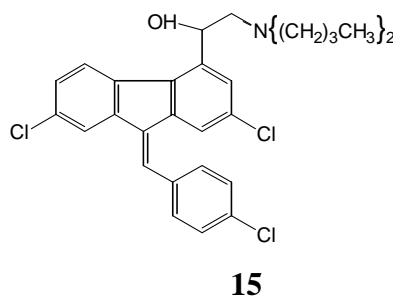
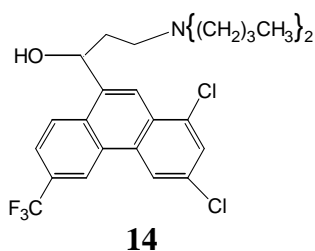

Artemisinin (**16**) is the anti-malarial principal isolated by Chinese scientists in 1972 from *Artemisia annua*, a medicinal plant from which is derived the traditional medicine qinghaosu (WHO, 1998). Two derivatives are widely used: the oil-soluble methyl ether artemether (**17**) and the water-soluble hemisuccinate derivative artesunate (**18**). These drugs are the most rapidly acting of known anti-malarials. They also have a broad time window of anti-malarial effect from ring forms to mature trophozoites. They produce rapid parasite clearance and are safe in clinical practice (Li *et al.*, 1989).



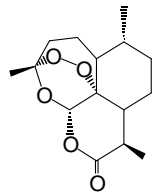

**16**

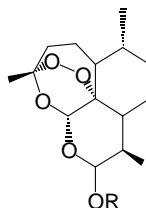

**17**, R = CH<sub>3</sub>

**18**, R =  $\text{C}(\text{O})\text{-(CH}_2\text{)}_2\text{CO}_2\text{Na}$

## 2.2 Combination Therapy with Anti-Malarial Drugs

The concept of combination therapy is based on the synergistic or additive potential of two or more drugs, to improve therapeutic efficacy and also delay the development of resistance to the individual components of the combination (WHO, 2001). There is a growing consensus that drug combinations are essential to the optimal control of malaria in developing countries more so as cases of increase in drug resistance continues to be experienced with existing chemotherapies (Guerin, 2002).

Fansidar<sup>®</sup> is a combination of sulfadoxine and pyrimethamine (WHO, 1984). These compounds have been used as chemotherapeutic agents in treatment of chloroquine-resistant malaria. However, recent studies have indicated resistance by *P. falciparum* in East Africa (Ogutu *et al.*, 2000). Proguanil/Atovaquone combination was released in Australia in 1998 under the brand name Malarone<sup>®</sup>. It showed a good efficacy for treatment of malaria caused by *P. falciparum* resistant parasite (Kremsner *et al.*, 1999). Maloprim<sup>®</sup>, a combination of dapsone and pyrimethamine has also been developed

although resistance to this drug is now widespread and its use is no longer recommended (Canfield *et al.*, 1995).

Coartem<sup>®</sup>, is a fixed dose combination of artemether (a rapidly acting, short-lived anti-malarial) and lumefantrine (a long resident drug also referred to as benflumetol). This drug is indicated for treatment of uncomplicated malarial episodes caused by pure or mixed *P. falciparum* infections. The combination confers mutual protection against resistance and prevents recrudescence after artemether therapy (White, 2004).

### **2.3 Anti-Malarial Compounds from Nature**

Secondary metabolites are chemical compounds derived from living organisms. The study of natural products involves isolation in a pure form of these compounds and investigation of their structure, formation, use and purpose in the organism. Secondary metabolites appear to function primarily in defense against predators and pathogens and in providing reproductive advantage as intraspecific and interspecific attractants. They may also act to create competitive advantage as poison of rival species (Fraquinho, 1994). A number of alkaloids, terpenoids, quinoids and phenolic compounds from higher plants have shown activity against protozoa (Phillipson and O'Neill, 1987). The majority of these compounds have been evaluated *in vitro* and in a few cases *in vivo* activity in animal models. Very few of the reported anti-malarial compounds have been assessed clinically. Several thousands of anti-plasmodial compounds from all classes of natural products have been isolated from different plants.

### 2.3.1 Alkaloids

Alkaloids are one of the major classes of compounds possessing anti-malarial activity. Despite the fact that alkaloids may be seriously toxic for the host, they are of major interest in finding new anti-parasitics (Philipson *et al.*, 1993).

#### 2.3.1.1 Quinoline Alkaloids

Quinine is one of the best alkaloids with anti-plasmodial activity (Kayser *et al.*, 2003). Other quinoline alkaloids have also shown anti-parasitic activity. From *Galipea officinalis* trunk bark different 2-substituted tetrahydroquinolines were isolated and evaluated on the *P. falciparum* strains (Jacquemonde-Collet *et al.*, 2002). The IC<sub>50</sub> were calculated after 24 and 72 hr of contact between compounds and the parasite culture, and ranged from 1.8 to 40 µg/ml for the chloroquine resistant strain. Galipinine (**19**) yielded the best anti-malarial effect (IC<sub>50</sub> 0.09 - 0.9 µg/ml) (Fournet and Munoz, 2002).

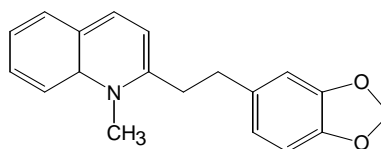

**19**

#### 2.3.1.2 Bisbenzylisoquinolines

Bisbenzylisoquinolines are present in many plant species, particularly in the families of Annonaceae, Berberidaceae, Menispermaceae and Hernandiaceae (Akendengue *et al.*,

1999). The species *Triclisia dictyophylla* (Menispermaceae) contains different bisbenzylisoquinolines alkaloids like pheanthine (1R, 1'R), isotetrandrine (1R, 1'S) which are active against *P. falciparum in vitro* with an IC<sub>50</sub> of 1.41 and 0.07 µg/ml, respectively (Partridge *et al.*, 1989). Tetrandrine (1S, 1S') (**20**) the enantiomer of pheanthine, was isolated from the roots of *Cyclea barbata* (Menispermaceae), possessing an IC<sub>50</sub> on *P. falciparum in vitro* of 0.179 µg/ml for strain W-2 (Lin *et al.*, 1993).

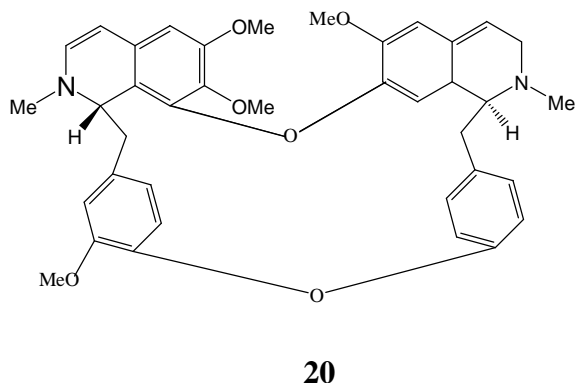

This observation demonstrated the importance of the stereochemistry of the chiral of these alkaloids. The therapeutic index of tetrandrine is not the most favourable for the eventual development of an anti-malarial drug, given its effects on the cardiovascular system and of anti-cancerous properties (Fournet and Muñoz, 2002).

Bisbenzyl isoquinolines have shown the potential as possible anti-malarial drugs, as potentiating agents of different commercial anti-malarial drugs and as resistance reversing agents (Fournet and Muñoz, 2002). The interaction of tetrandrine with chloroquine as well

as artemisinin was assessed *in vitro* by means of isobolograms, using both chloroquine-resistant (Indochina W2) and chloroquine-sensitive (5FCMSU1/Soudan) strains of *P. falciparum*. The concave feature of the isobologram curves obtained from these combinations, show that tetrandrine, chloroquine and artemisinin act synergistically against both strains. Using the resistant strain, tetrandrine lowers the  $CI_{50}$  of chloroquine 40-fold (Ye *et al.*, 1989). On the other hand, pheanthine is a chloroquine antagonist against the strain T9-96 of *P. falciparum* and does not show synergism in association with chloroquine against multi-resistant strain K1 (Ekong *et al.*, 1991).

#### **2.3.1.3 Naphthylisoquinoline Alkaloids**

Naphthylisoquinoline alkaloids, isolated from tropical lianas, are a group of alkaloids with high anti-parasitic potential. When tested *in vitro* and *in vivo* against *P. falciparum* they show activity (Kayser *et al.*, 2003). Extracts from *Triphophyllum peltatum* (Dioncophyllaceae) led to the isolation of dioncophylline B (**21**) and dioncophylline C (**22**), both exhibiting high anti-plasmodial activity (Francois *et al.*, 1997). Structure activity consideration indicates two possible criteria for anti-plasmodial activity: an **R** configuration at C-3 associated with absence of an oxygen substituent at C-6 and the absence of N-methylation (Francois *et al.*, 1994).

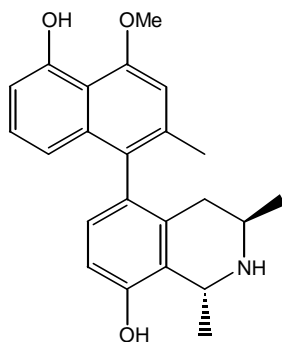

21

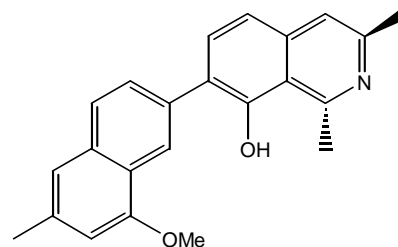

22

#### 2.3.1.4 Indole Alkaloids

A number of indolquinoline alkaloids have been isolated from *Cryptolepis sanguinolenta* (Periplocaceae) and tested for anti-plasmodial activity. Cryptolepin (**23**) showed variable effects ranging from 34 - 46% (Kirby *et al.*, 1995) to 80% reduction of parasitaemia (Grellier *et al.*, 1996).

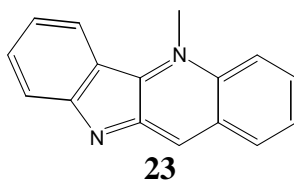

23

#### 2.3.2 Phenolics

Phenolic compounds are a huge and diverse group of aromatic compounds usually with hydroxyl groups. Phenol itself is the simplest member of the class, although it is not found in plants. Many phenolic compounds have three carbon side chains and are called "phenyl-propanoids". They include pigments, flavour compounds and tannins. They

probably function in defense against herbivores and in regulation of auxin transport. Attraction of insects and birds also play an important role in seed dispersal and pollination (Goodwin and Mercer, 1983).

### 2.3.2.1 Simple Phenols

Simple phenols that are widely distributed in nature have shown characteristic inhibition of malaria parasite growth. From *Hypericum calycinum* (Hypericaceae), a prenylated phloroglucinol derivative (**24**), inhibited *P. falciparum* growth with an EC<sub>50</sub> value of 0.88 µg/ml (Decosterd *et al.*, 1991). A coumarin derivative 5,7-dimethoxy-8-(3'-hydroxy-3'-methyl-1'-butene)-coumarin (**25**) isolated from *Toddalia asiatica* had IC<sub>50</sub> value of 16.2 and 8.8 µg/ml against chloroquine sensitive and resistant *P. falciparum* isolates, respectively (Oketch-Rabah *et al.*, 2000).

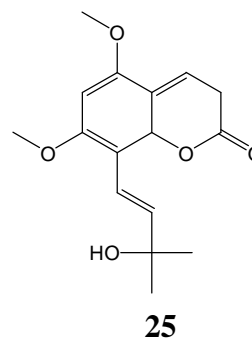
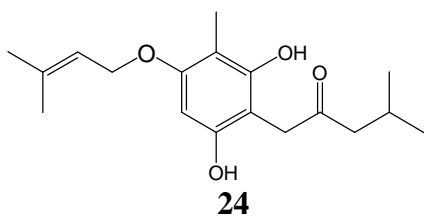

### 2.3.2.2 Chalcones and Aurones

Licochalcone A (**26**), from *Glycyrrhiza inflata*, has been tested against *P. falciparum* *in vitro* and *in vivo* (Chen *et al.*, 1994) and synthetic strategies have been developed to optimize drug action (Li *et al.*, 1995). Aurones (**27**), share structural similarities with

chalcones which explain their similar antiparasitic activity against *P. falciparum* (Kayser *et al.*, 2001).

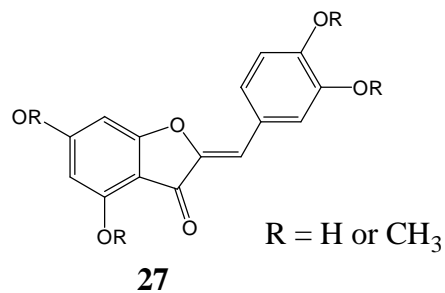
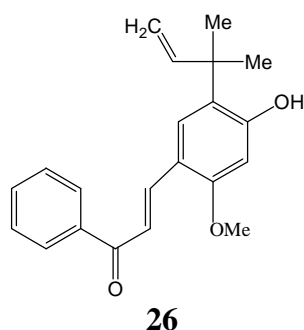

### 2.3.2.3 Flavonoids

Flavonoids are widely distributed in the plant kingdom (Kayser *et al.*, 2003). Artemetin (**28**) and casticin (**29**) act synergistically with artemisinin (Elford *et al.*, 1987). Both are methoxylated flavones and acts as inhibitors of L-glutamine uptake by infected macrophages. Also *Artemisia indica* which has the flavonoids sakuranetin (**30**) and 7-methoxyaromadendrin (**31**) show high anti-protozal activity (Ribiero *et al.*, 1997).

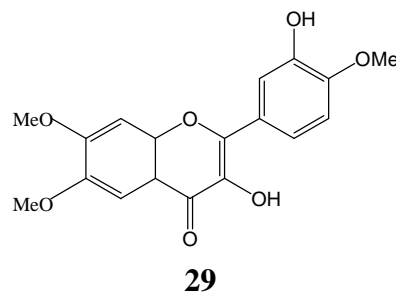
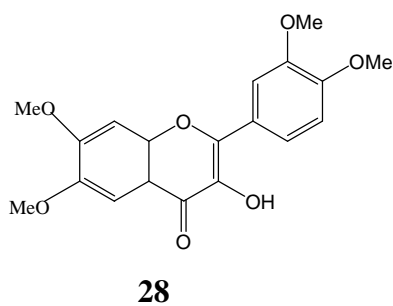



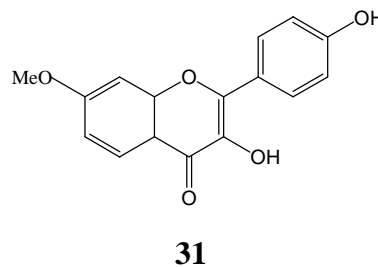
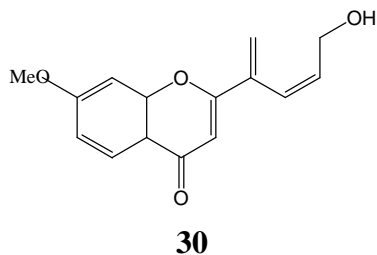

#### 2.3.2.4 Naphthoquinones

Naphthoquinones and other related quinoid compounds are one of the major natural product classes with significant activity against Plasmodium. Many have been isolated but their potential use has been limited by low bio-availability and high toxicity (Sepuvela-Boza and Cassels, 1996; Fournet *et al.*, 1992). Plumbagin (**32**), isolated from *Perabenensis sp.* (Euphorbiaceae), is active at  $IC_{50} = 0.27 \mu\text{g/ml}$  when tested against *P. falciparum* (Likhitwitayawuid *et al.*, 1998).

Semi-synthetic tetramethoxy and tetracetoxy derivatives of diospyrin (**33**) isolated from *Diospyros montana* (Ebenaceae), shows a 100-fold increase in activity in comparison to the genuine compound and are thus as effective against *P. falciparum* as chloroquine at  $IC_{50} = 0.21 \mu\text{g/ml}$  (Hazra *et al.*, 1995).

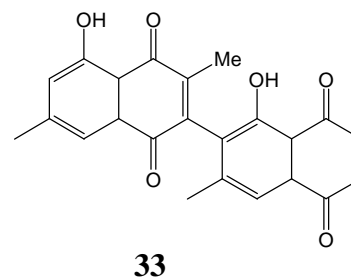
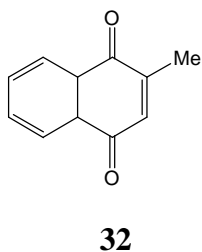

### 2.3.2.5 Anthraquinones and Xanthonones

This group is related to naphthoquinones in structure and biological activity. The main chemical difference between the groups is the tricyclic aromatic system with a para-quinoid substitute. Knipholone (**34**), a compound first isolated from *Kniphophia foliosa* (Asphodelaceae), three of its natural derivatives and seven structurally related compounds were assayed for anti-plasmodial activity (Dagne and Steglich, 1984; Bringmann *et al.*, 1999). All the phenylanthraquinones showed considerable activity with only little cytotoxicity, whereas the individual anthraquinone and phenyl moieties were completely inactive. Apart from Knipholone, the anthrone (**35**) was found to have good activity (Bezabih *et al.*, 2001).

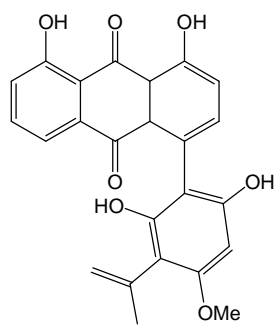

**34**

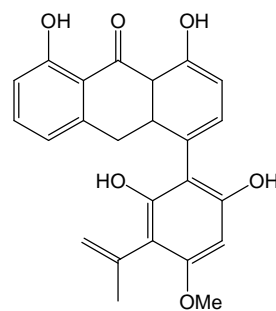

**35**

### 2.3.2.6 Quassinoids

Quassinoids are heavily oxygenated lactones with majority of C<sub>20</sub> basic skeleton named as picrasane. However, C<sub>18</sub>, C<sub>19</sub> and C<sub>25</sub> quassinoids are also known. A wide spectrum of biological properties has been reported for this class of compounds, of which anti-

neoplastic and anti-malarial have major importance (Polonsky, 1985). The quassinoids brusatol (**36**), bruceantin (**37**) and brucein (**38**) differ only in the nature of the ester moiety. Bruceantin showed most potent anti-malarial activity. The introduction of rigid alkyl groups such as gem-dimethyl, gem-methyl and isopropyl at C-23 also contributed to the enhancement of anti-malarial activity in brusatol and brucein (Anderson *et al.*, 1991; Sharma and Agarwal, 1995). Cedronin (**39**) belongs to the few quassinoids with a C<sub>19</sub> skeleton. Its IC<sub>50</sub> values for both chloroquine sensitive and resistant strains were similar implying that quassinoids may act upon malarial parasites by means of a fundamentally different mechanism from that of chloroquine. Cedronin possesses some of the structural requirements for cytotoxic activities, as an A-ring with unsaturated ketol at position 1 and 2, a lactone, and an oxide bridge between C-8 and C-15. C<sub>19</sub> quassinoid cedronin also exhibited lower selective toxicity against Plasmodium than against mammalian cells (Moretti *et al.*, 1994).

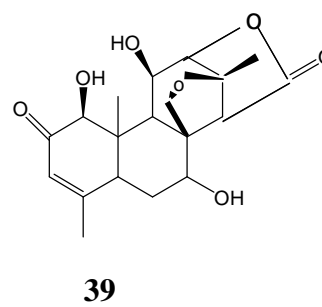
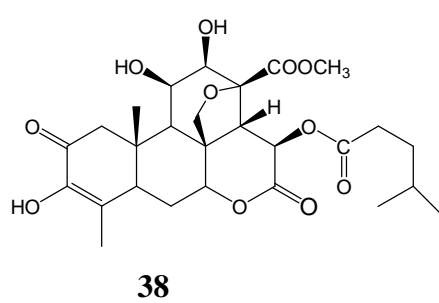
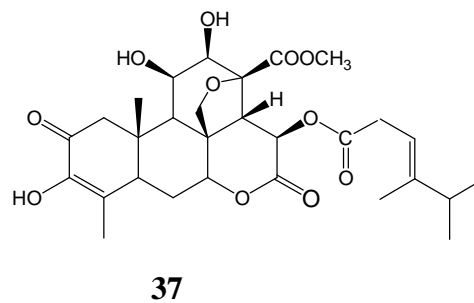
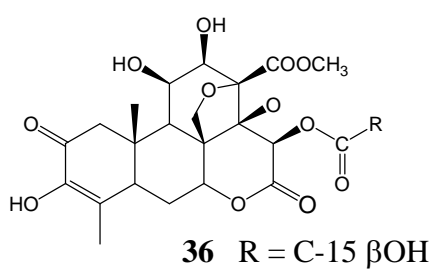

### 2.3.3 Terpenes

Terpenes are the generic name of a group of natural products, structurally based on the isoprene (isopentenyl) unit (**40**). They may also refer to oxygen derivatives of these compounds that are known as terpenoids, for example menthol (**41**).

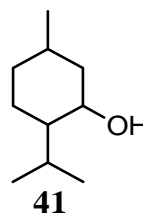
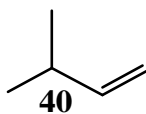

### 2.3.3.1 Monoterpenes

Simple monoterpenes for example espintanol (**42**) and piquerol A (**43**) show some activity against protozoan parasites (Hocquemiller *et al.*, 1991; Tandon *et al.*, 1991). Both espintanol and piquerol A isolated from *Oxandra espinata* (Annonaceae) exhibited an IC<sub>90</sub> of 25-100 µg/ml against *T. cruzi* strains and IC<sub>50</sub> of 100 µg/ml against *P. falciparum*, respectively (Kayser *et al.*, 1998).

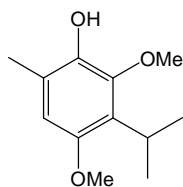

**42**

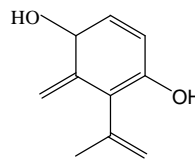

**43**

### 2.3.3.2 Sesquiterpenes

This class of terpenes contains three isoprene units. They are found in many living systems particularly in higher plants (Roberts, 1972). Sesquiterpene peroxides are chemically characterized by an endoperoxide bridge. The anti-parasitic mechanism is unclear. One theory involves interaction with heme and Fe (II) groups, reducing the peroxide functionality and generating radicals which kill the malaria parasite (Kanaan *et al.*, 2002). With the discovery and development of artemisinin (**16**) the anti-protozoal potential of sesquiterpenes has attracted renewed interest (Rayo *et al.*, 2000).

### 2.3.3.3 Diterpenes

Diterpenes are among the most widely distributed terpenes in the plant kingdom and are well known for their biological activity, however, most of them combine both high anti-parasitic activity as well as high toxicity for mammalian cells (Kayser *et al.*, 1998). However, Axisonitrile (**44**), a sesquiterpene derivative isolated from sponge *Acanthella klethra*, shows potent anti-plasmodial activity with no detectable cytotoxicity (Angerhofer *et al.*, 1999).

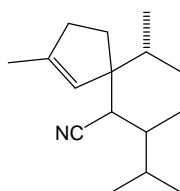

**44**

### 2.3.3.4 Triterpenes

These are compounds containing thirty carbon atoms made from six isoprene units. They are derived from squalene which in turn is formed upon head to head coupling of two sesquiterpenoid units (Connolly, 1972; Goodwin, 1981). Betullinic acid (**45**), also known for its anti-neoplastic effect, was identified by bio-guided fractionation to be the anti-plasmodial principle of *Triphophyllum peltatum* (Dioncophyllaceae) and *Ancistrocladus heyneanus* (Ancistrocladaceae). It had an EC<sub>50</sub> value of 10.46 µg/ml against *P. falciparum* *in vitro* and moderate cytotoxicity (EC<sub>50</sub> > 20 µg/ml) (Bringmann *et al.*, 1997; Majester-Sarvonia *et al.*, 1991).

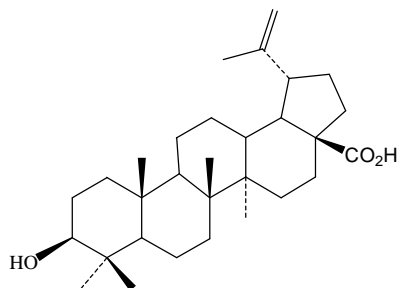

45

### 2.3.3.5 Limonoids

Limonoids are bitter terpenoids produced by species of Meliaceae. One well-known representative plant from this family is *Azadirachta indica*, the neem tree, widely used as an anti-malarial drug in Asia (Kayser *et al.*, 2003). Rochanakij *et al.* (1985) initially identified nimbolide (**46**) as the active anti-plasmodial principle of the neem tree (EC<sub>50</sub> 0.95 ng/ml for *P. falciparum* K). Subsequently, gedunin (**47**) was also found to be active *in vitro* against *P. falciparum* parasites with EC<sub>50</sub> value in the range of 0.72-1.74 μg/ml (Khalid *et al.*, 1989; Badam *et al.*, 1987).

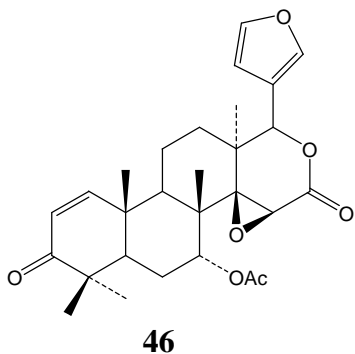

46

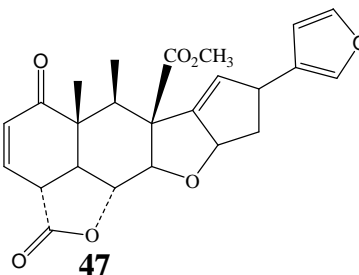

47

## **2.4 Anti-Malarial Plants in this Study**

*Microglossa pyrifolia* (Astereceae) and *Trimeria grandifolia* (Flacourtiaceae) plant species from Lake Victoria wetlands have been associated with treatment of a variety of diseases, from interviews conducted on traditional healers (unpublished report) and from literature review (Kokwaro, 1993). They are traditionally used by the local communities for treatment of a wide range of ailments including malaria related symptoms (Kokwaro, 1993). Ethno-botanical, pharmacological and chemical investigations of the selected medicinal plants have been summarized below.

### **2.4.1 *Microglossa pyrifolia* (Lam) Ktze (Astereceae)**

This plant is commonly known as *Nyabungu Odide* in the Luo community (Kokwaro, 1993). It is a climbing shrub of up to 6 m. Its branches are finely ribbed and leaves are alternating petiolate (Wild, 1975). Roots are pounded, soaked in water and used for the treatment of headache and colds. An infusion of the leaves is taken as a remedy for malaria. Pounded leaves are also used for the treatment of limb fractures (Kokwaro, 1993).

Previous work done on the aerial parts of *M. pyrifolia* had the following thirteen compounds elucidated. Acacetin (**48**), linoleic acid (**49**), E-phytol (**50**), benzyl 2,6 – dimethoxy benzoate (**51**), 3 –hydroxyoctadeca –9Z, 11E, 15Z trien –oic acid (**52**), 1-hydroxy- calamanene as a mixture of two isomers (**53**), others are furanoditerpenes: stritic acid (**54**), hardwickiic acid (**55**), 10 $\alpha$ -nidoresedic acid (**56**), and 10 $\beta$ -nidoresedic acid



(57). Several active fractions yielded 6E-geranylgeraniol –19-oic acid (58), 1-acetyl-6E-geranylgeraniol –19-oic acid (59), and sinapyl diangelate (60).

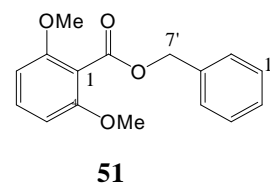
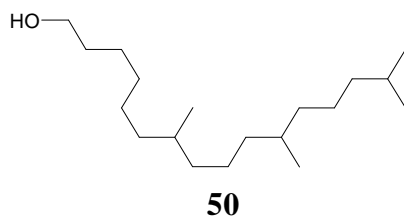
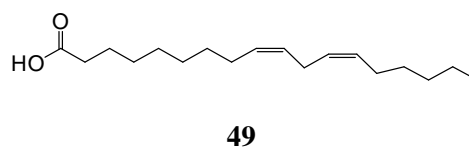
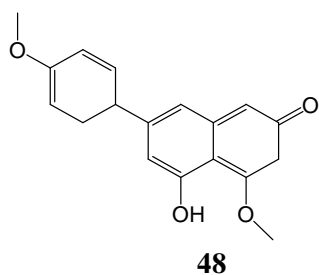

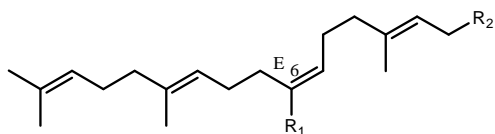
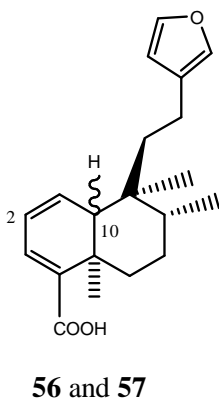
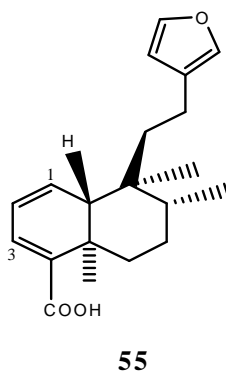
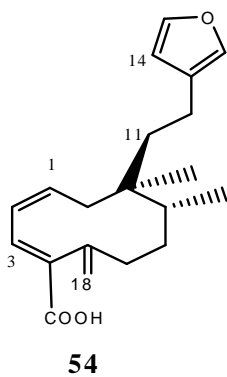
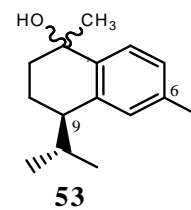
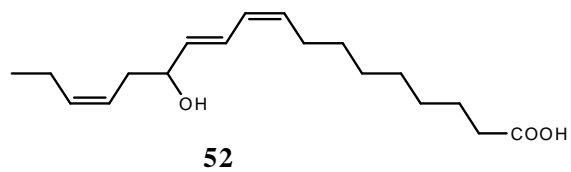

58 R<sub>1</sub> COOH

59 R<sub>1</sub> COOH

R<sub>2</sub> OH  
OCOCH<sub>3</sub>

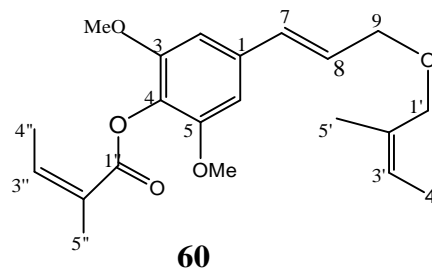

In the anti-plasmodial assay the compounds linoleic acid (**49**), E-phytol (**50**), 1,3-hydroxyoctadeca –9Z, 11E, 15Z trien –oic acid (**51**), and 6E-geranylgeraniol –19-oic acid (**58**), exhibited an activity against *P. falciparum* with IC<sub>50</sub> values between 2.5µg/ml and 13.7µg/ml. Among the active fractions the dirterpene 6E-geranylgeraniol –19-oic acid (**56**), was isolated, thus it was assumed that the aliphatic unsaturated compounds of *M. pyrifolia* represented the anti-protozoal principle of this species. The methanolic and aqueous extracts did not show any activity (Köhler *et al.*, 2002).

#### 2.4.2 *Trimeria grandifolia* (Hochst.) Warb (Flacourtiaceae)

*T. grandifolia* belongs to Flacourtiaceae family. The Flacourtiaceae is a large family consisting of some 89 genera and 1300 species found through out the tropical and temperate regions of the world (Floyd, 1989). The family is best known for “Cholmogra oil” obtained from the seeds of *Hydnocarpus* species which has been used for treatment of leprosy and other skin diseases (Hagnaeur, 1966).

Previous study of Flacourtiaceae has reported that the bark of *Casearia multinervosa* and leaves of *Xylosma terrae-reginae* showed an antitumor effect (Collins *et al.*, 1990). Plants in this family have been shown to contain clerodane and kolovane diterpene esters and phenolic glycosides, some of which have cytotoxic and insect anti-feedant activities (Beutler *et al.*, 2000). Flacourtiaceae is still an under explored family with diverse range of bio-active compounds (Waterman, 1996). *T. grandifolia* is commonly referred to as Wild Mulberry, they grow as small leafy trees or shrubs up to 8 m high, spineless, slightly hairy on leaf veins and white flowers (Wild, 1975). Dried leaf decoction of *T. grandifolia* is used traditionally for abdominal troubles (Hedberg *et al.*, 1983; Chhabra *et al.*, 1984) while gum from bark is used for healing of old wounds and mouth sores (Hedberg *et al.*, 1983). Compounds such as coumarins, sterols, tannins and terpenoids have been tested (Chhabra *et al.*, 1984). No information on the isolation work or anti-malarial study on this plant is available.

## **2.5 Justification**

Malaria is a significant threat to millions of people within the tropics. Various attempts to control the disease such as vector control, effective and prompt treatment and rapid application of control measures have not borne much fruit (Campbell, 1997). Despite the very successful intervention methods such as applying larvicidal agents, spraying of breeding areas with insecticides in Europe, USA, Cuba and other places, their extended use however has led to the emergence of insecticide-resistant mosquitoes. As the

development of an effective vaccine appears to be still a distant dream, presently malaria chemotherapy is the option at hand in managing the disease.

Current synthetic anti-malarials have not led to the achievement of malaria eradication due to increased cases of drug resistance against most of these drugs by *P. falciparum* parasite strains, adverse side effects of the drugs, and the high cost of some of the chemotherapeutics. Apparently, parasite resistance even to the newer anti-malarial agents like Halofantrine<sup>®</sup> has also been reported (Nkunya, 2002).

In view of multi-drug resistance of *P. falciparum* several efforts have been made to continue with search for new anti-malarial drugs, whereby plant natural products from herbal remedies used in malaria endemic areas have offered a promising source of such new drugs (Nkunya, 2002). Quinine, isolated from Cinchona bark was used as a template for chloroquine and mefloquine. More recently artemisinin, has been used as anti-malarial (Van Agtmael *et al.*, 1999; Robert *et al.*, 2002).

Vegetation around Lake Victoria region is diverse both in nature and uses with claims to possess medicinal value. The inhabitants also practice traditional and herbal remedies as an alternative choice of treatment of malaria. It is therefore, of interest to evaluate the effect of these two selected plants on *Plasmodium falciparum in-vitro*.

## **2.6 Null Hypothesis**

*M. pyrifolia* and *T. grandifolia* from Lake Victoria basin do not have potential anti-malarial compounds.

## **2.7 Objectives**

### **2.7.1 General Objective**

To identify the biochemical principles from *M. pyrifolia* and *T. grandifolia* used by traditional medicinal practitioners in Lake Victoria region, Nyanza Province and investigate their anti-plasmodial activity.

### **2.7.2 Specific Objectives**

1. To determine in-vitro anti-plasmodial activity on crude extracts of *M. pyrifolia* and *T. grandifolia*.
2. To determine the cytotoxicity of crude extracts *M. pyrifolia* and *T. grandifolia*.
3. To isolate and elucidate the chemical compounds from plant extracts.
4. To establish anti-plasmodial activity of the isolated compounds.
5. To determine drug interaction effect of the active pure compound(s) with chloroquine

## **CHAPTER 3**

### **3.0 MATERIALS AND METHODS**

#### **3.1 Materials, Reagents and Equipment**

##### **3.1.1 Reagents**

Acetic acid, citric acid, dextrose, Giemsa stain, glycerol and N-2-hydroxyethylpiperazine N-2-ethanesulfonic acid (HEPES) were purchased from Sigma Chemical Company, St. Louis, U.S.A. [<sup>3</sup>H]-Hypoxanthine, methanol, sodium hydrogen carbonate, Sodium chloride, Rosewell Park Memorial Institute 1640 (RPMI 1640) powdered medium were purchased from Gibco Laboratories, California, U.S.A. Culture gas mixture (92% N<sub>2</sub>, 5% CO<sub>2</sub>, 3% O<sub>2</sub>) was purchased from British Oxygen Company (BOC), Nairobi, Kenya. The organic solvents; acetone, butanol, petroleum ether, ethyl acetate, dichloromethane, chloroform, methanol and ethanol were purchased from Kobian, Kenya Limited. All solvents used for extraction, fractionation and purification were distilled to remove impurities and stored in 2.5 l amber bottles. Ethanol was also used in sterilization.

##### **3.1.2 Equipment**

Laminar flow hood, liquid scintillation counter, microscopes, refrigerators, incubator, gas-tight box, cell harvester, analytical balance with sensitivity of 0.1 mg, vacuum pump, centrifugal machine, adjustable volume Eppendorf micro-pipette, automatic pipette pump, vibro mixer and electrically heated water bath available at KEMRI laboratories were used.

### **3.1.3 Disposable Plastics and Glassware**

Anti-coagulant-free blood collecting bags and sterile gloves (Triflex®), 15 and 50 ml centrifuge tubes, (Brinkmann Instruments Company, Westbury, U.S.A), 50 and 150ml culture flasks, (Corning® U.S.A), microscope slides and cover slips (Sigma Chemicals Company, U.S.A), 0.45 and 0.22 µm filter units (Naglene Company, U.S.A). Serological Pasteur pipettes (Fischer Scientific, Pittsburgh, U.S.A) were acquired through Baxter Diagnostics, U.S.A.

### **3.1.4 Recycled Glassware**

Re-usable glassware, were soaked in hot water with liquid detergent, rinsed and washed thoroughly with tap water, distilled water and ethanol. They were then dried at 110 °C in an electric oven for at least one hour and allowed to cool to room temperature.

### **3.1.5 Sterilizing Materials**

Care was taken to keep all the materials for culture sterile. All culture experiments were carried out in a laminar flow hood. Sterilized Pasteur pipettes, lids and disposable pipettes were passed over a Bunsen burner flame several times before use. Ethanol (70%) was used to sterilize the hood and other equipment. The used Pasteur pipettes were put in 20% sodium hypochlorite to disinfect before washing. Disposable apparatus were similarly disinfected before being discarded.



## **3.2 Plant Materials**

### **3.2.1 Sampling**

*Microglossa pyrifolia* (Lam) Ktze (Asteraceae) and *Trimeria grandifolia* (Hochst.) Warb (Flacourtiaceae), being part of a continuing project were selected on the basis of ethnobotanical information combined with information in literature (Kokwaro, 1993). They were identified, authenticated by Mr. G. M. Mungai of East African Herbarium based at National Museum of Kenya. The voucher specimens cm 166 and cm 170 for *T. grandifolia* and *M. pyrifolia* respectively of plant materials collected around Lake Victoria region, were deposited in the East African Herbarium.

### **3.2.2 Extraction**

Dried powder (310 g) of *T. grandifolia* and (300 g) of *M. pyrifolia* leaves was soaked in 600 ml of hexane and placed in a shaker for 48 hr. The extract was filtered, the residue dried and soaked in 600 ml dichloromethane. The procedure was repeated with ethyl acetate and methanol. The filtered extracts were combined and solvent removed under reduced pressure. The dried samples were weighed and the yield noted. The samples were then stored in refrigerator (- 4°C) to be used when required.

## **3.3 Bioassays**

### **3.3.1 Cytotoxicity Assay**

Vero 199 cells obtained from CTMDR (KEMRI) cold bank, were cultured and maintained in Minimum Essential Medium (MEM) supplemented with 10% Fetal Bovine Serum (FBS). The cells were cultured at 37°C in 5% CO<sub>2</sub>, harvested by trypsinization, pooled in

a 50 ml vial and 100  $\mu$ l cell suspension ( $1 \times 10^5$  cell/ml) put into 2 wells of rows A-H in a 96-well micro-titer plate for one sample. The cells incubated at 37°C in 5% CO<sub>2</sub> for 24 hr to attach, the medium aspirated off from row H and 150  $\mu$ l of the highest concentration of each test samples (serial dilutions in MEM) added into the same row and a serial dilution was carried out up to row B. The experimental plates were incubated further at 37°C for 48 hr. The controls used were cells with no drugs, and medium alone. 3-(4, 5-dimethylthiazol-2-yl)-2, 5-diphenyltetrazolium bromide (MTT) reagent (10  $\mu$ l) was added into each well and the cells incubated for 2 - 4 hr until a purple precipitate was clearly visible under a microscope. The medium together with the MTT was aspirated off from the wells, Dimethylsulfoxide (DMSO) (100  $\mu$ l) added and the plates shaken for 5 min. The absorbance was measured for each well at 562 nm using a micro-titer plate reader (Mosmann, 1983). Cell viability (%) was calculated using the formula:

$$\text{Cell viability (\%)} = \frac{\text{Avg. abs. in duplicate drug wells} - \text{Avg. abs. blank wells}}{\text{Average absorbance control wells}} \times 100$$

This was done at each concentration. Concentration and cell viability (%) values were fed in the Grafit Software to give a dose-response curve and CC<sub>50</sub>.

### **3.3.2 *In-vitro* Anti-plasmodial Assay**

#### **3.3.2.1 Parasites**

Two strains of *Plasmodium falciparum* parasites (D6 and W2) were used. D6 is a chloroquine resistant while W2 is a chloroquine sensitive strain. These parasites were obtained from the WHO/TDR parasite bank at KEMRI, Kenya.

#### **3.3.2.2 Parasite Cultivation**

Parasite cultivation was based on the *in vitro* technique described by Trager and Jensen (1976). Cultivation was carried out aseptically in a laminar flow hood.

#### **3.3.2.3 Culture Preparations**

##### **3.3.2.3.1 RPMI 1640/ HEPES Medium**

This was prepared according to Trager and Jensen (1976). In brief, it contained 25 mM HEPES (5.94 g/l) and 10.5 g RPMI 1640-powdered medium (without *p* aminobenzoic acid (PABA) and lactic acid (LA) dissolved in 960 ml of distilled and autoclaved water. It was filtered and sterilized using a vacuum pump and 0.22 µm filters, and stored at 4°C before use within 4 weeks.

##### **3.3.2.3.2 Wash Medium (WM)**

The WM was prepared according to Rowe *et al* (1968) by mixing 95.8% v/v of the RPMI 1640 and HEPES medium and 4.2% v/v of 5% w/v sodium carbonate.

#### **3.3.2.3.3 Uninfected Erythrocyte**

The methods described by Trager and Jensen (1976) were adopted. In brief, uninfected blood group O Rhesus positive from KEMRI recruited volunteers was drawn into 15% (v/v) acid-citrate-dextrose (ACD). Enzyme-linked immunosorbent assay (ELISA) method was used to screen blood for human immune virus (HIV) and hepatitis B infections at Centre for Virology Research (CVR), KEMRI. Prior to blood donation, it was ascertained that the individuals had not contracted malaria or visited a malaria endemic area in the past two months. It was also ascertained that the donor had not taken any anti-malarial or antibiotic drugs. The blood was washed free of plasma and white blood cells before use in the culture by centrifugation at 3600 rpm for 10 min at 4°C. The plasma and buffer coat at the top of the cell pellet was aspirated and discarded. The red cell pellet was washed twice with 2 volumes of WM and the resulting suspension centrifuged at 3600 rpm for 10 min at 4°C. After the last wash, the packed cells were suspended in an equal volume of WM to obtain a haematocrit of 50%. The cells were exposed to a gas mixture (92% N<sub>2</sub>, 5% CO<sub>2</sub> and 3% O<sub>2</sub>) and stored at 4°C to be used within two weeks.

#### **3.3.2.3.4 Preparation of Human Serum**

The methods used were adopted from Trager and Jensen (1976). Briefly, blood from donors was collected aseptically into blood bags without anti-coagulants and allowed to clot by leaving it at room temperature for 90 min followed by an overnight storage at 4°C. The next day, the serum was carefully dispensed into sterile 50 ml centrifuge tubes and centrifuged at 3000 rpm for 10 min at 4°C. The serum was aseptically aliquoted into

sterile 10 ml snap-top tubes and heated in activated in a water bath at 56°C for 50 min The tubes were placed in upright position at -20°C overnight and then kept at -70°C until they were used.

#### **3.3.2.3.5 Complete Culture Medium with Serum (CMS)**

The methods used were adopted from Trager and Jensen (1976). Briefly, the CMS was prepared by mixing 86.22% (v/v) of RPMI 1640/HEPES, 3.78% (v/v) of 5% NaHCO<sub>3</sub> and 10% (v/v) human serum. The CMS was stored at 4°C and used within one week of preparation.

#### **3.3.2.3.6 Thawing of Malaria Parasites**

The methods used were adopted from Rowe *et al* (1968). Briefly, laboratory strains of malaria parasites preserved in liquid nitrogen were removed quickly thawed in water bath maintained at 37°C. The ampoules were surface sterilized with 70% ethanol. The stabilites were then gently agitated and transferred to a sterile 15 ml centrifuge plastic tube while still cold. The cells were centrifuged in a thermostated centrifugal machine at 1500 rpm for 5 min at 20°C. The supernatant (SN) was aspirated and discarded. The packed cells were immediately re-suspended in 0.3 ml of filter sterilized water 3.5 (w/v) sodium chloride in distilled autoclaved water (DAW) and immediately re-centrifuged and the supernatant aspirated and discarded again. This was to prevent osmotic lysis during the removal of the glycerol from cells. The parasites were finally re-suspended in 1 ml of CMS, centrifuged and supernatant aspirated and discarded.

### **3.3.2.3.7 Setting of the Culture**

The method described by Trager and Jensen (1976) was used. Briefly, after washing the parasites, the packed cell volume (pcv) of the parasitized erythrocytes was estimated and the volume of the RBC adjusted to 6% (v/v) (6% haematocrit (hct) by the addition of the CMS. The culture flasks were exposed to a gas mixture (92% N<sub>2</sub>, 5% CO<sub>2</sub>, and 3% O<sub>2</sub>) and incubated at 37°C for 24 hours. The medium was changed daily to remove the toxic compounds and the smears prepared after every 48 hours to determine the percentage parasitaemia (% P), the growth rate and to monitor contamination.

### **3.3.2.3.8 Determination of Parasitaemia and Parasite Growth Rates**

This was done according to Trager and Jensen (1976). In summary, thin blood smears were prepared using sterile plugged Pasteur pipettes after carefully aspirating and discarding the spent medium. A small drop of cell suspension was placed on a clean frosted glass microscope slide and thin film made by touching the drop with the edge of another slide held at 45 ° to the first. This spread the cells across the width of the slide with quick smooth movement. The blood films were air-dried, fixed with absolute methanol and stained with 10% Giemsa stain for 10 min. The slides were rinsed gently under flowing tap water, air-dried and observed in oil immersion under microscope (x100). Dilution or sub-culturing was usually done when percentage parasitaemia was high, and no contamination found on examining the slide under the microscope. The necessary volumes of culture 50% fresh erythrocytes and medium needed for 5 ml, 6% haematocrit culture were calculated from the formulae:

Culture Volume (CV) = 5/D

50% Erythrocytes Volume (EV) = 6/(50 - CV)

Medium volume = (CV + EV)

Where D is the reciprocal factor of the desired dilution factor (example D = 10 for 1:10 dilution). The appropriate volume of 50% RBC and medium were mixed together in new 25 ml culture flasks using sterile technique, gassed (92% N<sub>2</sub>, 5% CO<sub>2</sub> and 3% O<sub>2</sub>) and incubated for 20 min at 37°C. The desired volume of old culture was then added, gassed and incubated.

#### **3.3.2.3.9 Freezing of Parasites (Cryopreservation)**

The method of Rowe *et al* (1968) was adapted for cryopreservation of parasites to ensure enough supply of laboratory-adapted isolates as well as having manageable culture flasks. Thick smear was usually made to ascertain the cultures to be frozen are not contaminated. Briefly, the culture to be cryopreserved was transferred into 15 ml centrifuge tube and centrifuged at 1500 revolutions per min (400 g) for 5 min at 20°C. After aspirating the supernatant, packed cell volume (PCV) was estimated and one PCV of Rowe's cryosolution added. Aliquots of 0.25 ml were then put into 2 ml cryovials (Nunc®, U.S.A) placed in aluminium canes, which were placed into liquid nitrogen freezer.

#### **3.3.2.4. *In vitro* Drug Sensitivity Test**

The semi-automated micro-dilution technique of Desjardins *et al* (1979) for assessing *in vitro* anti-malarial activity as modified by Le Bras and Deloron (1983) was adapted in the

drug sensitivity studies for chloroquine and plant extracts against *P. falciparum* isolates. Briefly, the 96 flat-bottom well micro-titre plates (8 rows x 12 columns) were set such that all wells except control contain 25  $\mu$ l of doubling concentrations of drug solutions. Parasitized red blood cells (200  $\mu$ l) were added so that the total volume per well is 225  $\mu$ l.

#### **3.3.2.4.1 Preparation of Plant Extracts and Chloroquine for *In vitro* Bioassays**

The dry plant extract samples were retrieved from 4°C and dissolved in distilled water so that the final highest concentration in the micro-titre plates was 250  $\mu$ g/ml. For these experiments, 0.045 g of the plant extract was dissolved to a final volume of 20 ml (stock solution of 2,250  $\mu$ g/ml). Since the final volume in each well was 225  $\mu$ l, this stock solution was meant to give the first row concentration of 250  $\mu$ g/ml using the formula:

$$C_1V_1 = C_2V_2$$

Where  $C_1$  = initial concentration,  $V_1$  = initial volume,  $C_2$  = final concentration,  $V_2$  = final volume

Taking into account that the volume of each drug in each well was 25  $\mu$ l, the highest concentration (250  $\mu$ g/ml) was calculated so that:

$$2,250 \mu\text{g/ml} \times V_1 = 250 \mu\text{g/ml} \times 225 \mu\text{l}$$

$$V_1 = 250 \times 225 / 2,250 = 25 \mu\text{l}$$



This meant that 25  $\mu$ l of stock solution (2,250  $\mu$ g/ml) was used in the first row (Elueze *et al.*, 1996). Each drug was filter sterilized with syringe adaptable 0.22  $\mu$ m filters into sterile Bijoux bottles and stored at -2°C.

$$9 \mu\text{g/ml} \times V_1 = 1 \mu\text{g/ml} \times 225 \mu\text{l}$$

$$\begin{aligned} V_1 &= 1 \mu\text{g/ml} \times 225 \mu\text{l} / 9 \mu\text{g/ml} \\ &= 25 \mu\text{l} \end{aligned}$$

$$C_1 = 25 \mu\text{l} \text{ in the first row of the micro-titre plate}$$

For drugs that were not readily soluble in water, especially non-polar extracts of hexane and chloroform, they were dissolved in 50  $\mu$ l of DMSO (solvent concentration did not exceed 0.02%) and the volume adjusted to 20 ml with distilled water (Elueze *et al.*, 1996).

#### **3.3.2.4.2 Preparation of Micro-titre Plates**

This was done according to Desjardins *et al* (1979). Briefly, the 96 well flat-bottomed micro-titre plates (Nunc®, U.S.A) with covers were used for drug sensitivity tests. Under sterile conditions in the laminar flow hood (Belico Glass Inc., U.S.A), the plates were laid along the columns (1-12). Sterile de-ionized water (25  $\mu$ l) was added with a multi-channel pipette from row B to H, exempting row A. The drugs (50  $\mu$ l) were added in duplicate into wells of row A (each drug held two columns and one plate therefore accommodated 6 drugs in duplicate). Two-fold dilutions were done by transferring 25  $\mu$ l of the drug with a multi-channel micro-pipette from row A down to row G and the last 25  $\mu$ l from G wells discarded. Row H wells were exempted since they served as controls. Thus, row A wells had a concentration of 250  $\mu$ g/ml, B wells 125  $\mu$ g/ml as concentrations halved down to G,

which had the lowest concentration of 3.90625 µg/ml. The final volume per well was 25 µl. The plates were covered and kept at 4°C.

### **3.3.2.4.3 Addition of Parasites to the Pre-dosed Plates**

This was done according to Desjardins *et al* (1979). Briefly, the test culture at ring stage, having a percentage parasitaemia (% P)  $\geq$  4% and growth rate (GR)  $\geq$  3% was used for sensitivity tests. After examining the parasites under microscope, the % P of the test culture to be added to the wells of pre-dosed plates was adjusted to 0.4% and haematocrit (hct) adjusted to 1.5% with 50% RBC. The mixture (200 µl) was then added into each well except for H<sub>7</sub> to H<sub>12</sub>. If for instance the % P of the test culture (V<sub>i</sub>) was 4% and the number of plates to be set was 1 (n = 1), the following calculations were done to the cultures maintained at 5 ml and 6% haematocrit.

$$C_i V_i = C_f V_f$$

Where C<sub>i</sub> = initial concentration, V<sub>i</sub> = initial volume, C<sub>f</sub> = final concentration, V<sub>f</sub> = final volume

$$C_i = 4\%$$

$$C_f = 0.4\%$$

The volume of the plate (V<sub>f</sub>) was calculated as follows approximating 96 wells to 100 wells.

$$\begin{aligned} V_f &= 1 \text{ plate} \times 100 \text{ wells} \times 200 \text{ } \mu\text{l (volume of culture per well)} = 20000 \text{ } \mu\text{l} \\ &= 20 \text{ ml} \end{aligned}$$

The volume of the test culture (5 ml, 6% hct) which was used ( $V_i$ ) was calculated as follows:

$$C_i V_i = C_f V_f$$

$$4\% \times V_i = 4\% \times 20 \text{ ml}$$

$$\begin{aligned} V_i &= 0.4\% \times 20 \text{ ml} / 4\% \\ &= 2 \text{ ml} \end{aligned}$$

Since 5 ml has 6% hct, or  $6/100 \times 5 \text{ ml} = 0.3 \text{ ml}$  (100% RBC)

2 ml culture has 0.12 ml (100% RBC)

To adjust haematocrit to 1.5% of  $V_f$

$$1.5/100 \times 20 \text{ ml} = 0.3 \text{ ml (100\% RBC)}$$

But the  $V_i$  (2 ml) has 0.12 ml (100% RBC) and  $(0.3 - 0.12) \text{ ml} = 0.18 \text{ ml}$  (100% RBC) are required. This requires the addition of 50% RBC. Since the remaining 0.18 ml haematocrit is 100% RBC,  $0.18 \text{ ml} \times 2 = 0.36 \text{ ml}$  of 50% RBC is needed.

The final volume of 20 ml, needed is achieved by addition of CMS to 2 ml test culture and 0.36 ml of (50% RBC).

$$\text{CMS needed} = 20 \text{ ml} - (2 + 0.36) \text{ ml}$$

$$= (20 - 2.36) \text{ ml} = 17.64 \text{ ml}$$

This means that to set one plate using a culture whose % P = 4, you require 17.64 ml CMS, 0.36 ml (50% RBC) and 2 ml test culture, to achieve 0.4% P and 1.5% haematocrit.

The pre-warmed CMS (37°C) was put into 25 ml flask, the appropriate volume of 50% RBC added, flushed with 92% N<sub>2</sub>, 5% CO<sub>2</sub> and 3% O<sub>2</sub> gas mixture (BOC, Kenya) and kept at 37°C incubator for 5 min.

Using sterile technique in a laminar flow hood, the appropriate volume of test culture was added into the flask containing CMS and 50% RBC, and gently swirled in a circular motion to mix. The pre-dosed plates were warmed at 37°C for about 20 min, retrieved, placed in a laminar flow hood and the test culture put into sterile tissue culture dishes (Lux®, U.S.A). Using 1 - 200 µl pipette tips (Fisherbrand®, U.S.A) and a multi-channel pipette, aliquots of 200 µl were dispensed into the wells except for H7 to H12 (6 wells). To these, unparasitized red blood cells (URBC) were added (negative control) so that H1 - H6 served as parasitized red blood cells (PRBC) control (positive control) since they had no drug and the former served as UPRBC control. For 1 plate (6 wells):

$$\text{Volume} = 6 \text{ wells} \times 200 \mu\text{l} = 1200 \mu\text{l}$$

$$= 1.2 \text{ ml}$$

$$1.5 \% \text{ hct} = 1.5/100 \times 1.2 = 0.018 \text{ ml (100\% RBC)}$$

$$= 0.036 \text{ (50\% RBC)}$$

$$\text{CMS} = (1.2 - 0.036) \text{ ml}$$

$$= 1.164 \text{ ml}$$

0.36 ml of 50% RBC was mixed with 1.164 ml CMS and 200 µl were aliquoted into wells H7 to H12 using a multichannel pipette. The same procedure and calculations were done for n number of plates (n = 2, 3 .....etc).

#### **3.3.2.4.4 Incubation of the Plates**

This was done according to Desjardins *et al.* (1979). Briefly, after replacing the lids of micro-titre plates and agitating the plates gently, they were placed into gas-tight box,

which had a damp tissue to maintain a humid atmosphere in the chamber. The gas box lid was replaced and the air-tight box flushed with 92% N<sub>2</sub>, 5% CO<sub>2</sub> and 3% O<sub>2</sub> and incubated at 37 °C. After 48 hr, [G-<sup>3</sup>H] hypoxanthine (1 µCi/well) was pulsed in aliquots of 25 µl into each well and the plates incubated for a further 18 hr.

#### **3.3.2.4.5 Harvesting of Cells and Scintillation Counting**

This was done according to Desjardins *et al.* (1979). Briefly, the cells were harvested using a multiple semi-automatic cell harvester (Skatron®, Norway) onto glass fibre filters (Skatron®, Norway) for each row, from A to H. The filters were then dried at 37°C overnight, introduced into scintillation vials, and 1 ml of scintillation fluid (ecolume) added and the vials loaded into a liquid scintillation β counter (1211 Minibeta, England). Disintegrations per minute were calculated for each sample. The count per min (CPM) for each sample represented the incorporation of [G-<sup>3</sup>H] hypoxanthine into the parasite nucleic acids.

#### **3.3.2.4.6 Inhibitory Concentration (IC<sub>50</sub>)**

This was done according to Sixsmith *et al.* (1984). Briefly, the 50% inhibitory concentration (IC<sub>50</sub>) refers to the drug concentration inhibiting 50% of the parasite incorporation of [G-<sup>3</sup>H] hypoxanthine found in the drug-free PRBC wells. The UPRBC CPM values were taken as the background count and corrected CPM values of each well by subtracting UPRBC CPM values from each wells CPM values. To calculate IC<sub>50</sub>, the mid-point, the mid-point Y<sub>50</sub>) was calculated by the formula:

$$Y_{50} = (\text{PRBC CPM values} - \text{UPRBC CPM values})/2$$

IC<sub>50</sub> was calculated from the formula:

$$\text{IC}_{50} = \text{Antilog} (\text{Log } X_1 + [(\text{Log } Y_{50} - \text{Log } Y_1)(\text{Log } X_2 - \text{Log } X_1) / (\text{Log } Y_2 - \text{Log } Y_1)])$$

Where IC<sub>50</sub> = inhibitory concentration 50, X<sub>1</sub> and X<sub>2</sub> = lower and higher concentrations respectively, Y<sub>1</sub> = CPM values which correspond with X<sub>1</sub>, Y<sub>2</sub> = CPM values which correspond with X<sub>2</sub>.

### **3.3.3 Drug Combination Bioassay**

Template plates were used in preparation of drugs combinations. Briefly, test drugs were aliquoted into an extra plate in various ratios of blends. The combined test samples were well mixed and transferred to multiple daughter plates or test plates, such that 4 daughter plates were made per drug. Two plates were used for each of the plasmodial strain (D6 and W2). The other daughter plates were kept at -20 °C for running a repeat on a different day.

#### **3.3.3.1 Drug Interaction Experiments of Plant Extracts with Chloroquine**

The method described by Canfield *et al.* (1995) was adopted. Briefly solutions of initial concentrations 20-50 times the estimated IC<sub>50</sub> values was combined in various ratios of various drugs. Thus fixed ratios of predetermined concentrations needed to inhibit parasite growth by 50% (IC<sub>50</sub>) was used to determine the interaction of 2 drugs. A combination of TGC 2 and chloroquine phosphate (MW = 515.9) were assayed against chloroquine-resistant clone W2.. Single and combined drug solutions were dispensed into the 96 well

microtitre plates to give 9 combinations ratios of 90:10, 80:20, 70:30, 60:40, 50:50, 40:60, 30:70, 20:80, and 10:90 (CQ:TGC 2) (Fivelman *et al.*, 1999). Incubation and subsequent procedures were followed as previously described. Corresponding IC<sub>50</sub> values were determined for each drug alone and in combination using the method of Sixsmith *et al.*, (1984). The degree of synergy was evaluated according to the method of Berenbaum (1978). Briefly, fraction inhibition concentration (sum FIC) was calculated using the formula;

$$A_c/A_e + B_c/B_e = K,$$

where A<sub>c</sub> and B<sub>c</sub> are the equally effective concentrations (IC<sub>50</sub>) when used in combination, and A<sub>e</sub> and B<sub>e</sub> are the equally effective concentrations when used alone.

Sum FICs < 1 denote synergism, sum FICs ≥ 1 and < 2 denote additive interaction, Sum FICs ≥ 2 and < 4 denote slight antagonism, and Sum FICs ≥ 4 denote marked antagonism. Sum FICs < 0.5 indicate substantial synergism (Gupta *et al.*, 2002).

### **3.4 Fractionation, Purification and Identification**

Plant extracts were subjected to column chromatography (60 cm height \* 4 cm diameter) on silica gel. Columns packed with silica gel were left to stabilize for 6 hr.

Extracts were then loaded onto the column and solvent mixture of increasing polarity used to elute the fractions. Similar fractions were pooled together based on their retention factors from TLC analysis.

Further fractionation of the fractions with activity using CC, PTLC and re-crystallization led to isolation of pure compounds. The compounds were subjected to anti-plasmodial and cytotoxicity assays. Physical properties such as melting point was determined for the compounds isolated. IR and NMR spectroscopies was used for the chemical structure elucidation.

#### **3.4.1 Chromatography**

TLC and PTLC were performed on glass plates coated with G/UV<sub>254</sub> silica gel having fluorescent indicator and eluted with appropriate solvent system. CC was performed on silica gel 60<sup>6</sup> (70 -270 mesh) using gradient elution with solvents of increasing polarity.

#### **3.4.2 Melting Point**

Melting point was determined from Gallenkamp Melting Point Apparatus (Variable Heater) at JKUAT (Chemistry Department). These was repeated and value ranges recorded.

#### **3.4.3 Spectroscopy**

IR spectra were obtained from a Shimadzu Fourier Transformer Infrared (FTIR 8400) machine in nujol ( for liquids) and KBr (for solids) at JKUAT (Chemistry Department). NMR spectra were obtained on a Bruker 200 Spectrophotometer at 200 MHz for <sup>1</sup>H and 50 MHz for <sup>13</sup>C in deuterated methanol (MeOD) and deuterated chloroform (CDCl<sub>3</sub>) solvents at University of Nairobi (Chemistry Department). Residual



solvent peaks (MeOD) (4.84 & 48.63) and  $\text{CDCl}_3$  (7.25 & 77.00) were used as reference values for chemical shifts. DEPT and HMQC spectra were recorded from the same machine using the usual pulse sequences.

### **3.5 Isolation of Compounds from Leaves of *Trimeria grandifolia* (Flacourtiaceae).**

#### **3.5.1 Methanol Extract**

The methanol extract (8.0 g) was subjected to fractionation by column chromatography on silica gel with ethyl acetate:methanol gradient (95:5 - 5:95) giving 80 x 50 ml fractions. These were pooled on the basis of their  $R_f$  values and concentrated *in vacuo* to give fractions 1 - 15 (TGC<sub>15</sub>), 16 - 29 (TGC<sub>29</sub>), 30 - 42 (TGC<sub>42</sub>), 43 - 50 (TGC<sub>50</sub>), 51 - 69 (TGC<sub>69</sub>), and 70 - 80 (TGC<sub>80</sub>). Fraction TGC<sub>50</sub> which had a higher anti-plasmodial activity ( $\text{IC}_{50}$  25.00  $\pm$  1.68 on D6) compared to other tested fractions was subjected to preparative thin layer chromatography (PTLC) which yielded amongst others TGC (p 12), this was further subjected to reverse phase PTLC to afford four compounds; TGC 1, TGC 2, TGC 3, and TGC 4 (Scheme 1). The compounds were subjected to spectroscopic analysis (IR,  $^1\text{H}$ NMR and  $^{13}\text{C}$ NMR).

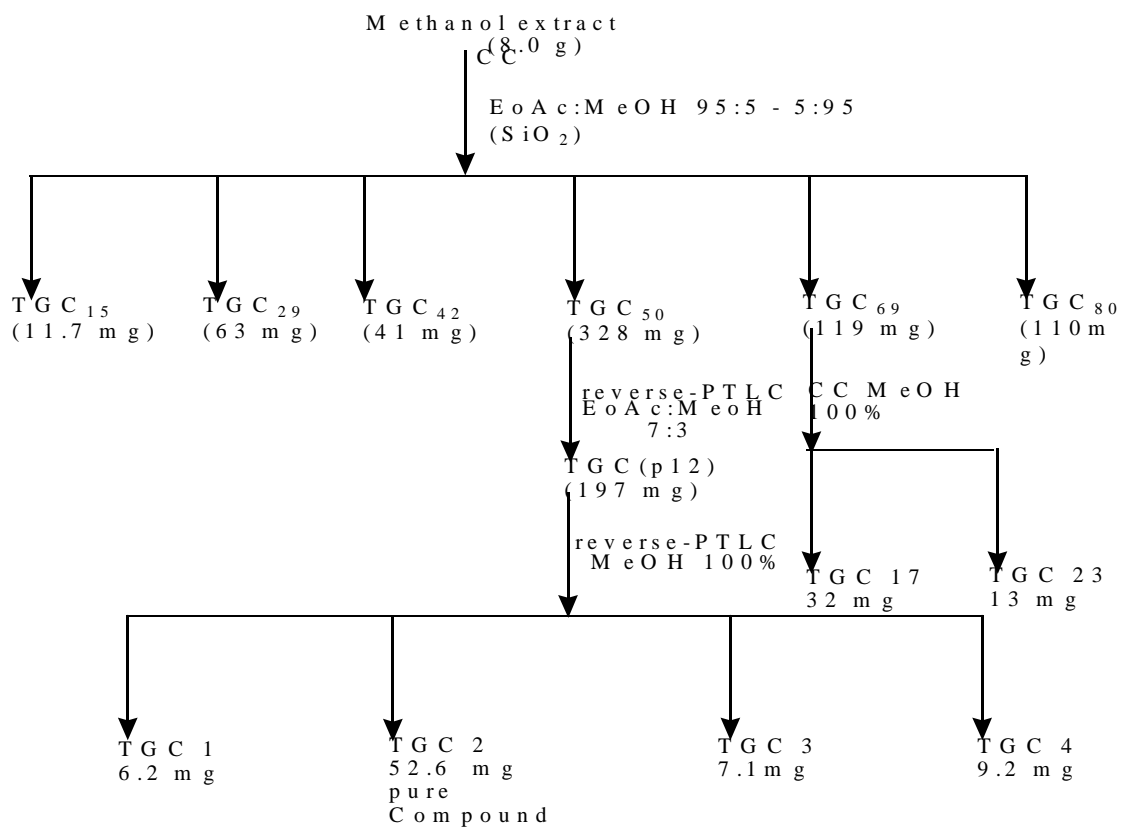

**Scheme 1: Isolation of compounds from the methanol extract of *T. grandifolia* leaves.**

### 3.5.1.1 Acid Hydrolysis of TGC 2

TGC 2 (5.0 mg) in MeOH (20 ml) was refluxed in 8% HCl for 2 hr at 100°C. The mixture was then concentrated and 2 ml H<sub>2</sub>O was added followed by neutralization with 10% NaHCO<sub>3</sub>. The aglycone was extracted with CHCl<sub>3</sub> 3 ml x 3 times. The H<sub>2</sub>O phase was evaporated under reduced pressure to yield a sugar molecule.

### 3.5.2 Dichloromethane Extract

The dichloromethane extract (6.2 g) was subjected to column chromatography over silica gel using gradient elution of using hexane:dichloromethane (95:5–5:95) followed by dichloromethane:ethylacetate (95:5-50:50). Eight fractions were collected. Fraction T1 was further subjected to column chromatography and yielded colourless needle-like crystals TGP 33 (6 mg). Fraction T4 (160 mg) was subjected to PTLC (3 times) on Hexane: DCM 1:1 to yield TG' 4 (6.7 mg). The fraction T5 (1.0 g) was loaded to a smaller column and eluted with Hexane: CH<sub>2</sub>Cl<sub>2</sub> 95:5 to get TG 5 (14 mg). This was further passed on a narrow column over silica gel with 100% methanol. This resulted in a pure TG4 (5.1 mg) (Scheme 2).

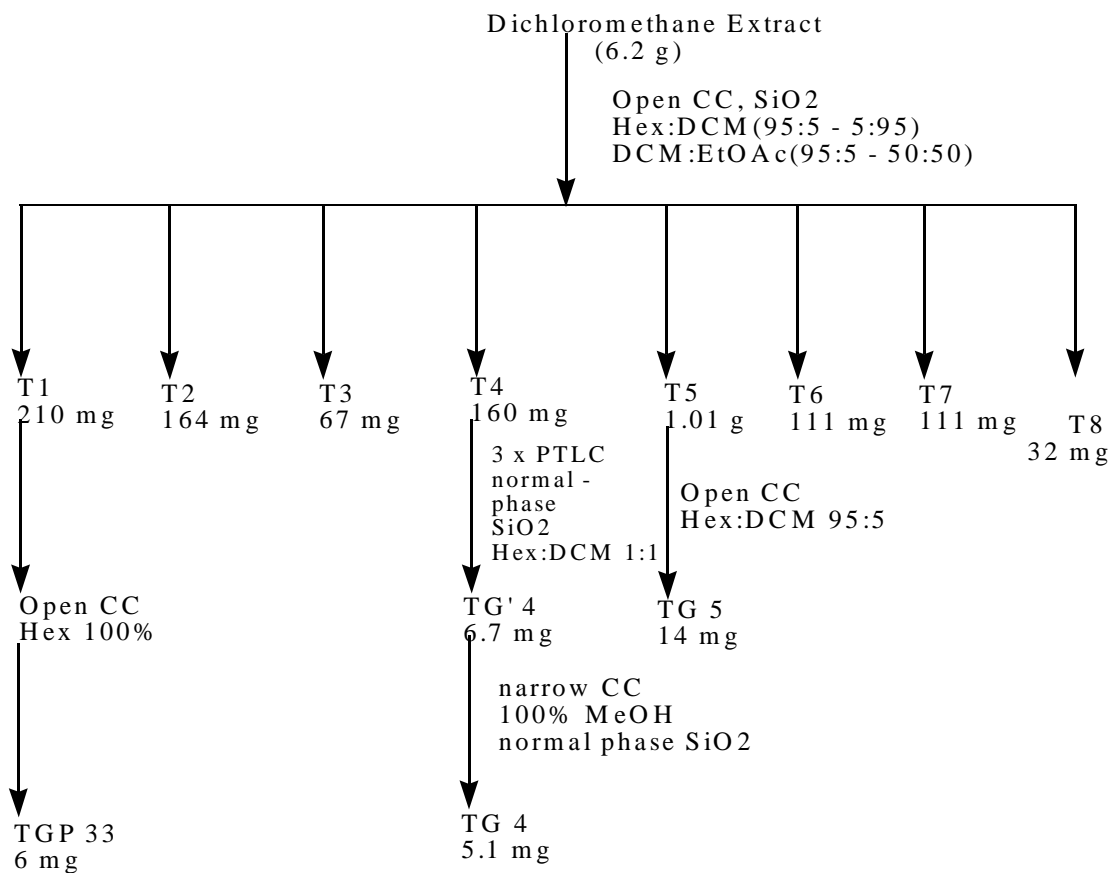

**Scheme 2: Isolation of compounds from the dichloromethane extract of *T. grandifolia* Leaves**

### 3.5.2.1 Lieberman–Burchard reaction: Test for Presence of Steroids

A few crystals of TGP 33 were dissolved in chloroform and a few drops of concentrated sulphuric acid added to it followed by addition of 2 – 3 drops of acetic anhydride.

### 3.6 Isolation of Compounds from *Microglossa pyrifolia* (Astereceae) Leaves

#### 3.6.1 Chloroform Extract

Chloroform extract (6.0 g) was subjected to fractionation by vacuum liquid chromatography on silica gel with hexane:chloroform: gradient elution (95:5-5:95) and chloroform:ethylacetate (95:5-50:50) giving 40 x 150 ml fractions. These were pooled on the basis of their  $R_f$  values and concentrated *in vacuo* to give six fractions 1 – 5 (MPC<sub>5</sub>), 6 - 17 (MPC<sub>17</sub>), 22 – 24 (MPC<sub>22</sub>), 25 - 29 (MPC<sub>29</sub>), 30 – 37 (MPC<sub>37</sub>), and 38 – 40 (MPC<sub>40</sub>). Only fraction MPC<sub>29</sub> was taken for further purification since the rest were obtained in small amounts. MPC<sub>29</sub> (1.2 g) was subjected to column chromatography on normal phase silica gel with 100% chloroform. Fractions MPC' 17 and MPC '30 obtained were further purified on PTLC to avail compounds MPC''<sub>7</sub> (9 mg), MPC''<sub>12</sub> (4.3 mg) and MPC''<sub>8</sub> (14.2 mg) as shown in Scheme 3.

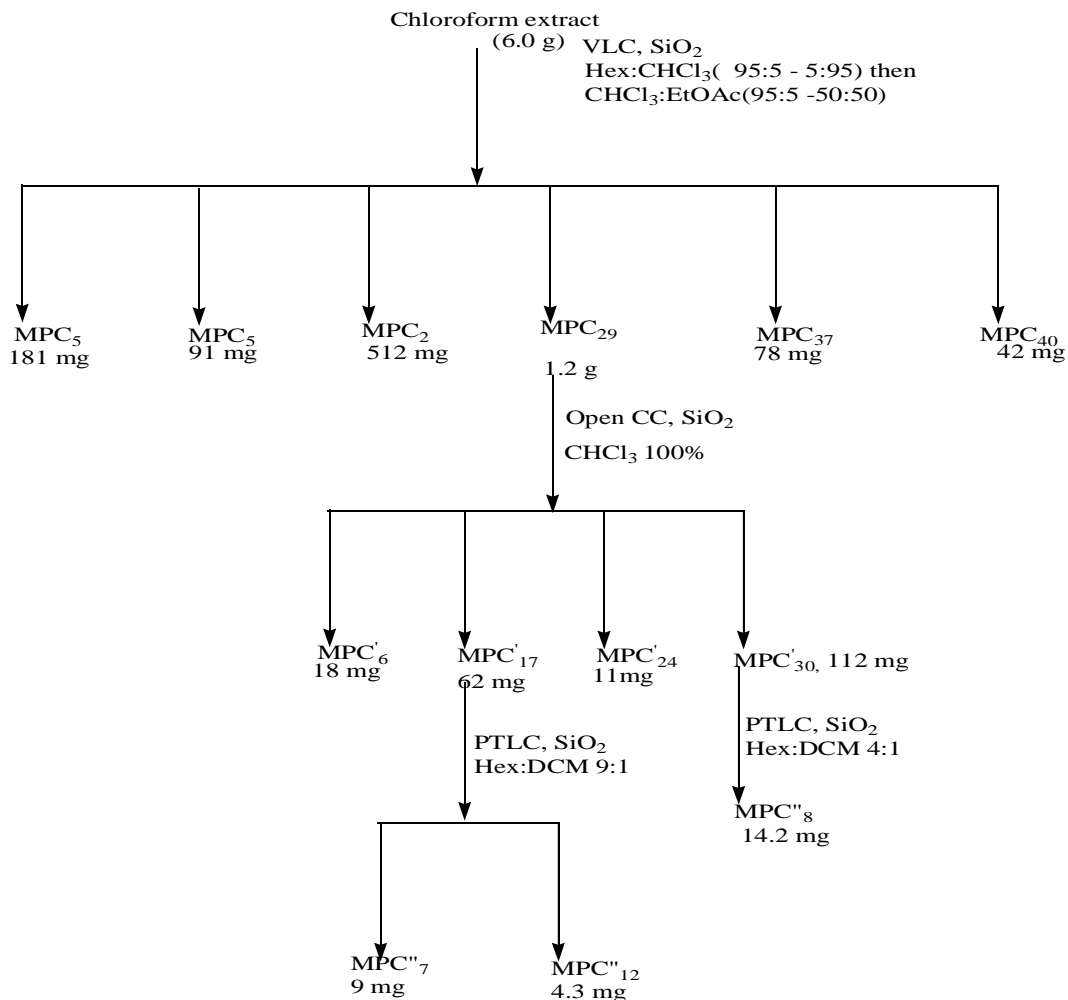

**Scheme 3: Isolation of compounds from the chloroform extract of *M. pyrifolia* leaves**

### 3.6.2 Methanol Extract

Methanol extract (22.0 g) was subjected to multiple solvent partitioning on a 500 ml separating funnel with chloroform, ethyl acetate and butanol to give 4 x 200 ml fractions. The EtOAc and n-BuOH extracts were obtained in small amounts and therefore not pursued further. The chloroform extract (6.72 g) was further subjected to fractionation on

column chromatography and gradient elution performed using Chloroform:Ethylacetate (95:5 – 5:95) followed by Ethylacetate:Methanol (95:5 - 50:50). Fractions 1 – 7 (MP<sub>8</sub>) were pooled on the basis of their similar R<sub>f</sub>. MP<sub>8</sub> was dissolved on dichloromethane and on re-crystallization formed white crystals coded MPC 1. Four compounds (MPC 1, MPC 2, MPC 3 and MPC 4) were obtained through preparative thin layer and column chromatography coupled with re-crystallization of the chloroform extract (scheme 4).

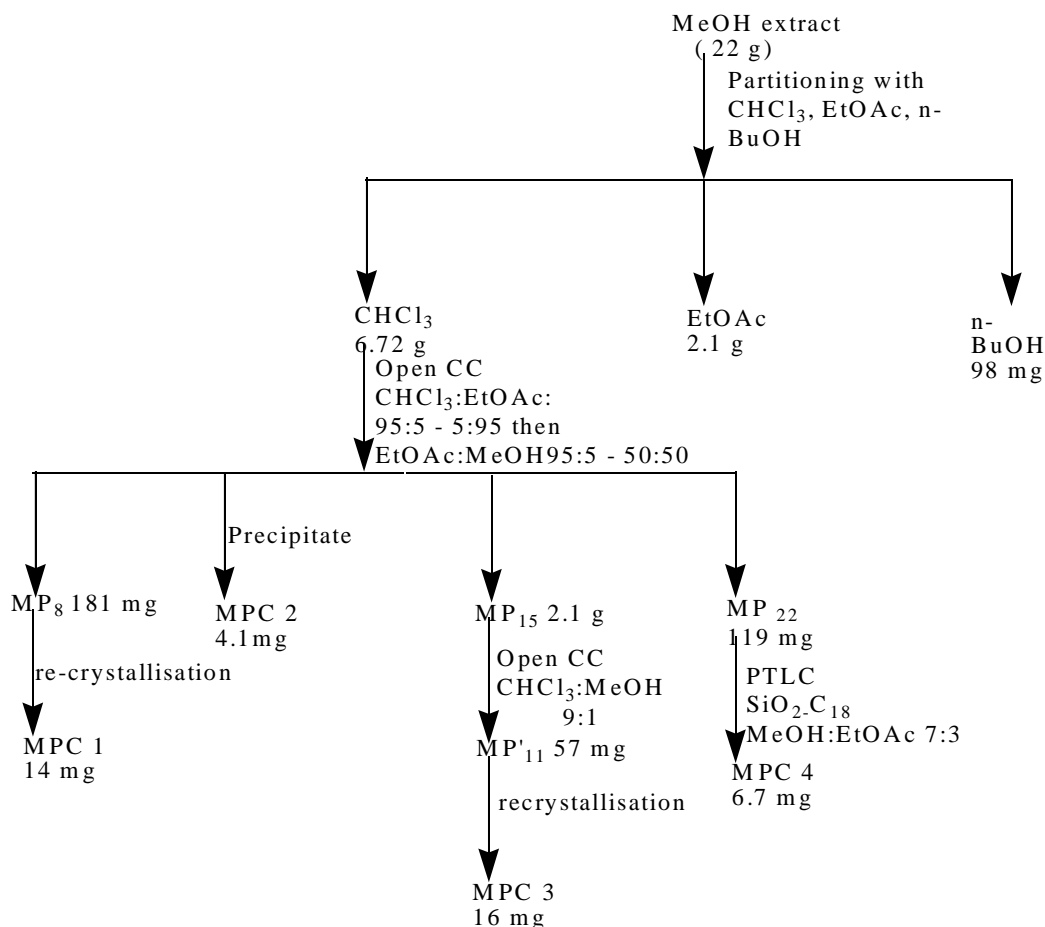

**Scheme 4: Isolation of compounds from the methanol extract of *M. pyrifolia* leaves**

## CHAPTER 4

### 4.0 RESULTS AND DISCUSSIONS

#### 4.1 Extraction

Successive extraction on both dried leaves of *Microglossa pyrifolia* (Asteraceae) and *Trimeria grandifolia* (Flacourtiaceae) was carried out and the percentage yield obtained as summarized in Table 1 below.

$$\text{Yield (\%)} = \left( \frac{X}{Y} * 100 \right)$$

Where  $X$  = Total mass of the extract obtained and  
 $Y$  = Total mass of dried plant material

**Table 1: The yield % of dried extracts of *M. pyrifolia* and *T. grandifolia* leaves**

Species	Extract	Weight (g)	Yield %
<i>T. grandifolia</i>	Hexane	1.8	0.6
	Dichloromethane	12.9	4.3
	Ethyl acetate	3.4	1.1
	Methanol	30.3	10.1
<i>M. pyrifolia</i>	Hexane	3.6	0.8
	Chloroform	29.7	6.6
	Ethyl acetate	6.2	1.3
	Methanol	43.6	9.7

The percentage yield of the methanol extracts was generally high compared to that of other used extracts. Methanol, due to its high polarity is able to extract from a wide range



of polar fractions in the plant material and some of the non-polar substances compared to Hexane, Dichloromethane/Chloroform or Ethyl acetate. After extraction with either chloroform or dichloromethane, the % yield for subsequent ethyl acetate extract was low for both *T. grandifolia* and *M. pyrifolia*. This shows that both chloroform and dichloromethane has the ability to extract most compounds extracted by ethyl acetate due to their close polarities.

## 4.2 Bioassays

This included cytotoxicity tests on crude extracts and the anti-plasmodial *in vitro* screening of crude extracts, semi-pure and pure compounds.

### 4.2.1 Cytotoxicity Tests

The crude extracts of *T. grandifolia* were screened for toxicity on Vero 199 cells. The (%) cell growth was calculated at different concentrations of dose-response curve and CC<sub>50</sub> obtained using excel sheet adapted from the Sixsmith formula (Sixsmith *et al.*, 1984) Table 2.

**Table 2: Cytotoxicity (CC<sub>50</sub>) of crude extracts for *T. grandifolia* and *M. pyrifolia***

Species	Extract	CC <sub>50</sub> µg/ml
<i>T. grandifolia</i>	Methanol	75.91
	Dichloromethane	>500
	Hexane	>500
<i>M. pyrifolia</i>	Methanol	124.21
	Chloroform	211.16
	Hexane	>500

Podopyllum resin was used as the standard cytotoxin with cytotoxicity at CC<sub>50</sub> 66.6 µg/ml.

Plant extracts are considered active if they exhibit cytotoxicity ( $CC_{50}$ ) up to 20  $\mu\text{g/ml}$  (Zirihi *et al.*, 2005).  $CC_{50}$  of all the extracts tested were  $> 20 \mu\text{g/ml}$  implying that there is less chances for the extract to destroy the Vero cells. The fact that the extracts are not able to destroy the cells is of important consideration when carrying out cytotoxicity studies alongside the anti-plasmodial study. If the plant extracts are cytotoxic on cells ( $CC_{50} \leq 20 \text{ mg/ml}$ ), the cells will be destroyed making the environment for parasite not conducive and consequently killing it. Thus one may see “anti-plasmodial” activity yet the extract is not affecting the parasite.

#### **4.2.2 Anti-plasmodial Screening of Crude extracts**

The crude extracts of *M. pyrifolia* and *T. grandifolia* were screened for *in vitro* anti-plasmodial activity against two *P. falciparum* isolates (D6 and W2, CQ-sensitive and resistant, respectively). The mean inhibitory concentration ( $MIC_{50}$ ) for the extracts is summarized in Table 3. Chloroquine diphosphate was used as the standard drug.

**Table 3: *In vitro* anti-plasmodial Activity (IC<sub>50</sub>) of crude extracts on two *P. falciparum* strains**

Species	Extract	CQ-sensitive <i>P. falciparum</i> (W2) IC <sub>50</sub> (µg/ml)	CQ-resistant <i>P. falciparum</i> (D6) IC <sub>50</sub> (µg/ml)
<i>M. pyrifolia</i>	CHCl <sub>3</sub>	23.59 ± 0.85	30.05 ± 0.97
	EtOAc	14.76 ± 1.80	25.03 ± 0.51
	CH <sub>3</sub> OH	1.59 ± 0.07	2.50 ± 0.15
<i>T. grandifolia</i>	CHCl <sub>3</sub>	32.23 ± 0.88	41.03 ± 1.12
	EtOAc	33.12 ± 0.11	49.34 ± 0.17
	CH <sub>3</sub> OH	17.16 ± 0.03	19.21 ± 2.18

Chloroquine diphosphate used as control with IC<sub>50</sub> 7.59 ± 0.39 µg/ml

Activity of crude extracts were considered high if IC<sub>50</sub> ≤ 10 µg/ml, moderate between 11 and 50 µg/ml and low between 51 and 100 µg/ml. IC<sub>50</sub> exceeding 100 µg/ml was considered inactive (Muregi *et al.*, 2003). Methanol extract for *M. pyrifolia* exhibited high activity against both D6 (IC<sub>50</sub> 1.59 ± 0.07 µg/ml) and W2 (2.50 ± 0.15 µg/ml) strains amongst the extracts tested. Similarly, the methanol extract of *T. grandifolia* showed moderate activity (IC<sub>50</sub> 17.16 ± 0.03 µg/ml) and (IC<sub>50</sub> 19.21 ± 2.18 µg/ml) on D6 and W2 strains respectively compared to those of ethyl acetate and chloroform. For all the extracts, there was higher activity against the CQ sensitive strain (D6) compared to CQ resistant strain (W2). However, this is not always the case with all extracts (Muregi *et al.*, 2003).

### 4.2.3 *In vitro* Anti-plasmodial Screening of Pure and Impure Compounds

The pure and semi-purified compounds isolated from *M. pyrifolia* and *T. grandifolia* were screened for *in vitro* anti-plasmodial activity against two *P. falciparum* isolates (W2 and D6). The IC<sub>50</sub> obtained are summarized in the Table 4

**Table 4: *In vitro* anti-plasmodial activity (IC<sub>50</sub>) of pure and semi-pure compounds *M. pyrifolia* and *T. grandifolia* against *P. falciparum* (W2 & D6).**

Plant Species	Extract	Compounds/Fractions	D6	W2
<i>M. pyrifolia</i>	Chloroform	MPC 12	>50.00	>50.00
		MPC 24	18.21 ± 3.81	25.06 ± 9.20
		MPC 8	22.71 ± 1.91	21.04 ± 2.74
	Methanol	MPC 1	19.45 ± 2.17	29.31 ± 1.91
		MPC 2	27.11 ± 1.18	24.22 ± 2.51
		MPC 3	11.12 ± 2.31	24.17 ± 6.09
<i>T. grandifolia</i>	Methanol	TGC 2	9.78 ± 3.2	14.4 ± 1.35
		TGC (44 – 50)	25.00 ± 1.68	39.07 ± 6.47
	Dichloromethane	TG 4	>50.00	>50.00
		TG 5	>50.00	>50.00
		TGP 33	14.27 ± 2.13	19.32 ± 2.56

Chloroquine diphosphate used as control with IC<sub>50</sub> 7.59 ± 0.39 µg/ml.

According to laboratory criteria used at KEMRI, pure and semi- compounds were considered to have high activity at IC<sub>50</sub> < 1 µg/ml, moderate activity at IC<sub>50</sub> 1- 5 µg/ml, low activity at IC<sub>50</sub> 5 - 10 µg/ml and not active at IC<sub>50</sub> > 10 µg/ml . Compound TGC 2 had an appreciable activity on D6 (IC<sub>50</sub> 9.78 ± 3.2 µg/ml). In general, methanol crude extracts of both *T. grandifolia* and *M. pyrifolia* exhibited a high anti-plasmodial activity compared to those of their respective pure and semi-pure compounds. This could be

explained that anti-plasmodial activity for the latter may have been lost in the process of fractionation and purification. Since compound TGC 2 exhibited an appreciable activity on D6 (IC<sub>50</sub> 9.78 ± 3.2 µg/ml) among the compounds tested, it was considered for *in vitro* interaction studies with CQ diphosphate to determine their potential effects.

#### 4.2.4 *In vitro* Drug Interaction Studies

*In vitro* drug interaction studies of TGC 2 with chloroquine against *P. falciparum* W2 (CQ resistant strain) was as previously described (Muregi *et al.*, 2004). The sum FIC values were calculated according to Berenbaum, (1978). The results are shown in Table 5 below.

**Table 5: Interaction of TGC 2 with chloroquine**

Combination ratios	90:10	80:20	70:30	60:40	50:50	40:60	30:70	20:80	10:90
Sum FIC	1.56	1.52	1.37	1.38	1.12	1.69	1.44	1.31	1.29

The interaction between TGC 2 and chloroquine was seen to be additive at all concentration ratios. Additive interaction and synergism highlights the interest in combinations of plants for the treatment of malaria. As much as synergism permits the quantity of each drug to be reduced, the same does not apply with the additive interactions. However, both interactions are effective means to counter drug resistance in anti-malarial chemotherapy (White, 2004). Ideally, combination chemotherapy for malaria should take advantage of synergistic interactions as this would enhance therapeutic efficacy and lower the risk of resistance emergence. On the other hand, if drug

combinations are antagonistic, the efficacies of such regimens are compromised and chances of resistance development and spread increases, allowing the weakly resistant clones to survive and be transmitted (Chawira *et al.*, 1987).

### 4.3 Structure Elucidation

#### 4.3.1 Compounds Isolated from *T. grandifolia*

The following compounds were isolated and identified from both dichloromethane and methanol extracts of *T. grandifolia*

##### 4.3.1.1 Idesin [6-hydroxy-2-(hydroxymethyl)phenyl $\beta$ -D-glucopyranoside] TGC2 (61).

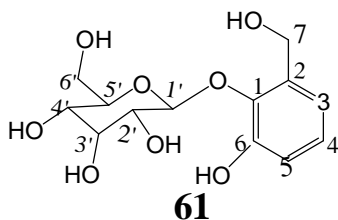

This compound was isolated as a brown gum and observed as a dark brown spot on TLC plate following a vanillin-sulphuric acid spray. The IR spectrum (Appendix 1) showed absorption peaks at  $\lambda_{\max}$  3409(OH), 1635(C=C-). The  $^1\text{H}$ ,  $^{13}\text{C}$ , DEPT and HMQC NMR data is summarized in Table 6.

**Table 6. NMR (field, MeOD) data for Idesin [6-hydroxy-2-(hydroxymethyl)phenyl  $\beta$ -D-glucopyranoside] TGC2 (61).**

Position	$\delta^1\text{H}_{\text{obs}}$	$\delta^1\text{H}_{\text{lit}}^a$	$\delta^{13}\text{C}_{\text{obs}}$	$\delta^{13}\text{C}_{\text{lit}}^b$	DEPT	HMQC
1	-	-	144.5	144.2	C	
2	-	-	136.7	136.2	C	
3	6.84	6.86(d)	121.2	121.3	CH	H-3
4	6.95	6.99 (t)	126.8	126.7	CH	H-4
5	6.77	6.86 (d)	117.4	117.4	CH	H-5
6	-	-	150.8	150.3	C	
7	4.73 – 4.64	4.79 (d) 4.63 (d)	60.6	60.5	CH <sub>2</sub>	H-6
1'	4.56	4.62 (d)	106.9	106.3	CH	H-1'
2'	3.86	3.60 (t)	75.4	75.0	CH	H-2'
3'	3.69 – 3.60	3.53 – 3.43 (m)	78.0	77.5	CH	H-3'
4'	3.69 – 3.60	3.53 – 3.43 (m)	71.3	70.9	CH	H-4'
5'	3.39 – 3.26	3.35 (m)	78.5	77.9	CH	H-5'
6'	3.86 – 3.78	3.90 (dd) 3.73 (dd)	62.6	62.2	CH <sub>2</sub>	H-6'

<sup>a</sup> and <sup>b</sup> assignments according to Chou *et al.* (1997).

The <sup>1</sup>H NMR spectra (Appendix 2) revealed three signals for the tri-substituted aromatic protons at  $\delta$  6.95 (t, J = 7.6 Hz), 6.84 (d, J = 7.8 Hz) and 6.77 (d, J = 7.8 Hz). The <sup>13</sup>C NMR spectrum (Appendix 3) showed 13 carbon resonances that were assigned using DEPT (Appendix 4) and HMQC (Appendix 5) as 2 methylene and 8 methine groups. The remaining 3 were quaternary carbons. The <sup>1</sup>H NMR experiments showed the benzylic methylene proton resonating at  $\delta$  4.73 (d, J = 14 Hz) and 4.64 (d, J = 14 Hz). The five signals in the <sup>13</sup>C NMR spectrum resonating in the range of  $\delta$  60 – 80 associated with protons at  $\delta$  3.26 – 3.86 and a methine at  $\delta$  106.9 indicated the presence of sugar moiety in the molecule. In addition, a signal at  $\delta$  4.56 (d, J = 7.0 Hz) was observed and assigned to anomeric proton (H-1'). The large coupling constant, J = 7.0 Hz was a characteristic for

an axial – axial coupling, thus showing that the sugar moiety was  $\beta$ -linked to the aglycone (Alam *et al.*, 1996). All this information was in close agreement with the literature value for Idesin (Chou *et al.*, 1997) and therefore TGC 2 was identified as Idesin (**61**). This compound was first isolated from the fruits of *Idesia polycarpa* and has been shown to inhibit lipopolysaccharide induced nitric oxide production in BV2 microglia at concentrations from 1 $\mu$ M to 100  $\mu$ M (Kim *et al.*, 2006).

#### 4.3.1.1.1 Acid hydrolysis of TGC 2

The presence of the sugar moiety in this compound was further confirmed by acid hydrolysis of TGC 2. The yielded sugar compared well with the authentic sample of glucose on TLC plate (TLC, EtOAc/MeOH/H<sub>2</sub>O 7:1:2, R<sub>f</sub> 0.13).

#### 4.3.1.2 Lupenone [Lup-20(29)-en-3-one] TG 4 (**62**)

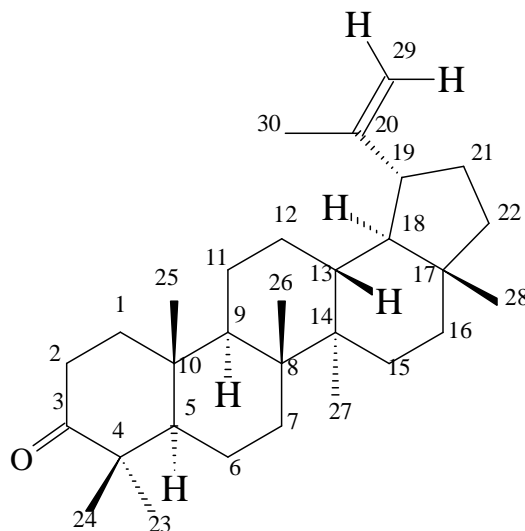



Compound TG 4 was obtained as yellow viscous liquid that after re-crystallization with methanol formed white crystals melting point (mpt) in the range of 168 – 172 °C. This compared well with the reported mpt 170 - 171°C (Razden *et al.*, 1988). TLC analysis using silica gel showed a single spot at  $R_f = 0.19$  ( $n\text{-C}_6\text{H}_{14}$ :  $\text{CH}_2\text{Cl}_2$  3:2) on spraying with vanillin sulphuric acid. The IR spectrum (Appendix 6) showed the presence of a carbonyl group at  $1705\text{ cm}^{-1}$ . The  $^1\text{H}$  NMR spectrum (Appendix 7) of TG 4 indicated the proton signals due to seven tertiary methyls [ $\delta_{\text{H}}$  1.67, 1.05, 1.01, 0.94, 0.91, 0.86 and 0.78]. The above information was regarded as a characteristic for pentacyclic triterpenes (Razden *et al.*, 1988). The signals for olefinic protons at  $\delta_{\text{H}}$  4.68 (1H, d,  $J = 2.6$  Hz) and  $\delta_{\text{H}}$  4.57 (1H, brqd,  $J = 2.6$  and 2.2 Hz) compared well with those of isopropenyl unit ( $-\text{C}(\text{CH}_3) = \text{CH}_2$ ),  $\delta_{\text{H}}$  4.69 (1H, d,  $J = 2.1$  Hz) and  $\delta_{\text{H}}$  4.57 (1H, brqd,  $J = 2.1$  and 1.2 Hz) in lupenone (Razden *et al.*, 1988). The rest of the proton signals were in a complex mass of multiplets spread between  $\delta_{\text{H}}$  0.83-2.45 due to methyl protons. The  $^{13}\text{C}$  NMR spectral data (Table 7, Appendix 8) compared well with the previously reported data of lupenone (Razden *et al.*, 1988). These comparison exhibited quaternary carbons at [ $\delta_{\text{C}}$  151.1, 47.2, 42.7, 42.7, 40.7, 36.8) and although the quaternary carbon for the carbonyl group was not observed in the  $^{13}\text{C}$  NMR spectra, the IR spectra indicated its presence], five methine carbons ( $\delta_{\text{C}}$  55.1, 49.9, 48.4, 48.1, 38.8) eleven methylene carbons ( $\delta_{\text{C}}$  109.2, 39.9, 39.8, 35.6, 34.3, 33.7, 29.8, 27.4, 25.3, 21.6, 19.8) and seven methyl carbons ( $\delta_{\text{C}}$  26.8, 21.2, 19.5, 18.4, 16.1, 15.9, 14.6) were quite discernible.

**Table 7: Comparison of <sup>13</sup>C NMR spectral data for compounds TG 4 and lupenone.**

Position	TG4 <sup>a</sup> , δ <sub>c</sub> (ppm)	Lupenone <sup>b</sup> , δ <sub>c</sub> (ppm)
1	39.8	39.6
2	34.3	34.1
3	-	217.9
4	48.1	47.2
5	55.1	55.8
6	19.8	19.6
7	33.7	33.5
8	40.9	40.7
9	49.9	49.7
10	37.1	36.8
11	21.6	21.4
12	25.3	25.1
13	38.8	38.1
14	40.9	42.7
15	27.6	27.4
16	35.7	35.6
17	43.1	42.7
18	48.4	48.2
19	48.1	47.8
20	151.1	150.5
21	29.9	29.8
22	40.1	39.9
23	26.8	26.6
24	21.2	21.0
25	16.1	15.8
26	15.9	15.4
27	14.6	14.4
28	18.2	18.0
29	109.5	109.2
30	19.5	19.2

<sup>a</sup>50 MHz, in CDCl<sub>3</sub>; <sup>b</sup> 63 MHz, in CDCl<sub>3</sub> (Razden et al., 1988).

Compound TG4 was therefore proposed to be a lupenone (**62**). Isolation of lupenone has been reported from a number of plants families from the root, leaves and stem barks extracts. It was previously identified as a constituent of stem bark stem of *Caraipa*

*densiflora* (Guttiferae) (Lima *et al.*, 1972). Lupenone has also been isolated from the leaves of Deer Tongue spp. (compositae) (Appleton and Enzell, 1971), and roots of *Alibertia macrophylla* (Rubiaceae) (Bolzani *et al.*, 1991), and as constituent of the whole plant of *Caralluma buchardii* (Asclepiadaceae) (Castro *et al.*, 1980). However, this is the first time to be isolated in this species of *T. grandifolia*.

#### 4.3.1.3 $\beta$ – Sitosterol [3 $\beta$ -stigman-5-en-3-ol] TGP 33 (63)

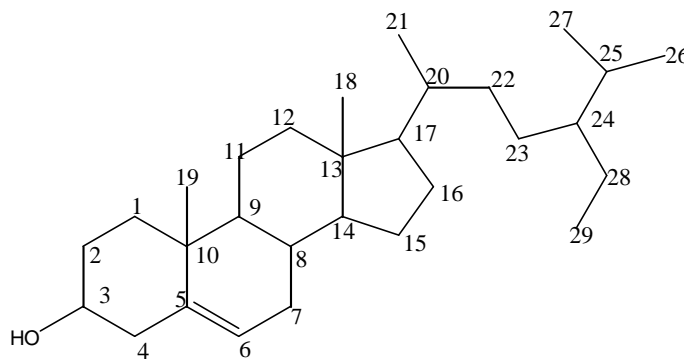

### 63

TGP 33 was isolated as colourless needle-like crystals, mp 138 – 140 °C. These crystals were easily soluble in chloroform and gave a positive response to the Liebermann-Burchard test for steroids. The IR spectrum (Appendix 9) showed a broad band at  $\nu$  3425  $\text{cm}^{-1}$  (OH) and tri-substituted double bonds (2939, 1659 and 1057  $\text{cm}^{-1}$ ). The 200 MHz  $^1\text{H}$  NMR spectrum of TGP 33 (Appendix 10) showed methyl signals within a complex mass of spectrum in the region  $\delta$  0.67 – 1.07. The signals for carbinylic and olefinic proton appeared at  $\delta$  3.47 (1H, m) and 5.32 (1H, m). The  $^{13}\text{C}$  NMR spectrum (Appendix 11) contained resonances of 29 carbon atoms which were assigned by DEPT (Appendix 12) and HMQC (Appendix 13) techniques as six methyl groups, eleven methylene groups,

nine methane groups of which one ( $\delta$  71. 8) was oxygenated and three quaternary carbon atoms at  $\delta$  (see Table 8 for complete  $^{13}\text{C}$  NMR data). The oxygenated atom was deduced to be C-3 based on biosynthetic arguments. This shows indicates that triterpenoids and isopentenoids, composed of thirty carbon atoms are built up of six isoprene units derived from squalene, presumably via ring opening of squalene-2,3-epoxide (oxidosqualene). This is followed by a concerted cyclisation (Abe *et al.*, 1993). Because of this biosynthetic origin, they are all hydroxylated at C-3 position (Wendt *et al.*, 2000).

**Table 8:**  $^{13}\text{C}$  NMR (50 MHz) data for  $\beta$ -sitosterol [ $3\beta$ -stigman-5-en-3-ol] TGP 33 (**63**) in  $\text{CDCl}_3$

C	$^{13}\text{C}$ $\delta_{\text{obs}}$	$^{13}\text{C}$ $\delta_{\text{lit}}^{\text{c}}$	DEPT	HMQC	C	$^{13}\text{C}$ $\delta_{\text{obs}}$	$^{13}\text{C}$ $\delta_{\text{lit}}^{\text{c}}$	DEPT
1	37.2	37.2	CH <sub>2</sub>		16	28.2	28.2	CH <sub>2</sub>
2	31.6	31.6	CH <sub>2</sub>		17	56.7	56.0	CH
3	71.8	71.8	CH	3.47 (m, H-3)	18	11.9	11.8	CH <sub>3</sub>
4	42.2	42.2	CH <sub>2</sub>		19	18.7	18.8	CH <sub>3</sub>
5	140.7	140.7	C		20	36.1	36.1	CH
6	121.7	121.7	CH	5.33(d, H-6)	21	19.8	19.8	CH <sub>3</sub>
7	33.9	33.8	CH <sub>2</sub>		22	26.0	29.2	CH <sub>2</sub>
8	31.9	31.8	CH		23	33.9	33.7	CH <sub>2</sub>
9	50.1	50.0	CH		24	42.2	42.3	CH
10	36.5	36.5	C		25	29.1	29.0	CH
11	21.1	21.0	CH <sub>2</sub>		26	19.4	19.4	CH <sub>3</sub>
12	39.7	39.7	CH <sub>2</sub>		27	19.0	18.9	CH <sub>3</sub>
13	45.7	45.7	C		28	24.3	24.3	CH <sub>2</sub>
14	56.8	56.7	CH		29	12.0	12.0	CH <sub>3</sub>
15	23.0	23.0	CH <sub>2</sub>					

<sup>c</sup>Assignments according to Kirira, 2004; Conolly and Hill, 1994.

#### 4.3.1.3.1 Liebermann – Burchard Test on TGP 33

The colour change as a result of this reaction from violet, blue and finally green confirmed a positive steroid test of TGP 33 (Abisch and Reichstein, 1960).

From these physical, chemical and spectral analysis,  $\beta$ -sitosterol (**63**) was proposed.  $\beta$ -sitosterol is found in many higher plants such as wheat germ (*Triticum*) and the root bark

of *Calotropis gigantea* (Habib, 2007) where it plays important role in the membranes of plant cells (Harbone and Herbert, 1993).

#### 4.3.1.4 Friedelanol MP 24 (64)

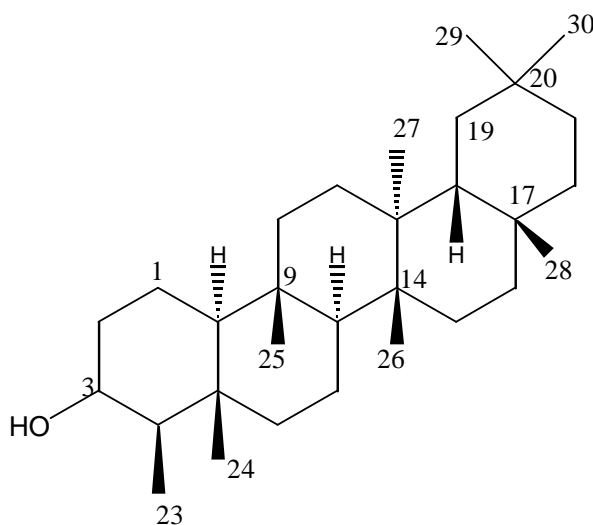

#### 64

MP 24 was obtained as white crystals mp 293 - 294°C. The IR spectrum of MP 24 (Appendix 14) exhibited an absorption maximum of 3479  $\text{cm}^{-1}$ , which was assigned to as hydroxy stretching. The  $^1\text{H-NMR}$  data of MP 24 (Appendix 15) showed methyls at  $\delta$  0.711 - 0.947 and one C-3 proton at  $\delta$  3.77 (1H, m). The  $^1\text{H-NMR}$  data did not allow much analysis of the hindered signals, however, a doublet ( $J = 7.8\text{Hz}$ ) centred at  $\delta$  0.856 ppm characteristic of methyl group at position C-23 of friedelane compounds was observed (López-Pérez *et al.*, 2007). The  $^{13}\text{C-NMR}$  of MP 24 (Appendix 16) revealed 30 carbon atoms, including 8 methyls, 11 methylenes, 5 methines and 6 quaternary carbons. The H-C assignments were determined from the HMQC spectrum (Appendix 17). The structure of MP 24 was also determined by comparison with literature data (Table 9). Thus MP 24 was identified as friedelanol (**64**) (Samaraweera *et al.*, 1983).

**Table 9:**  $^{13}\text{C}$  NMR (50 MHz) data for Friedelanol MP 24 (**64**) in  $\text{CDCl}_3$

C	<sup>13</sup> C δ <sub>obs</sub>	<sup>13</sup> C δ <sub>lit</sub> <sup>d</sup>	DEPT	HMQC	C	<sup>13</sup> C δ <sub>obs</sub>	<sup>13</sup> C δ <sub>lit</sub> <sup>d</sup>	DEPT
1	15.8	15.8	CH <sub>2</sub>		16	36.1	36.1	CH <sub>2</sub>
2	35.3	35.2	CH <sub>2</sub>		17	29.7	29.3	C
3	72.8	72.7	C-OH	3.72 (m, H-3)	18	42.8	42.9	CH
4	49.1	49.2	CH		19	35.5	35.6	CH <sub>2</sub>
5	41.3	41.2	C		20	28.2	28.2	C
6	42.8	41.8	CH <sub>2</sub>		21	32.3	32.9	CH <sub>2</sub>
7	17.5	17.6	CH <sub>2</sub>		22	39.3	39.3	CH <sub>2</sub>
8	53.2	53.2	CH		23	11.6	11.6	CH <sub>3</sub>
9	37.1	37.8	C		24	16.4	16.4	CH <sub>3</sub>
10	61.3	61.4	CH		25	18.2	18.2	CH <sub>3</sub>
11	35.5	35.6	CH <sub>2</sub>		26	18.6	18.6	CH <sub>3</sub>
12	32.8	32.9	CH <sub>2</sub>		27	20.1	20.1	CH <sub>3</sub>
13	38.0	38.2	C		28	32.1	32.1	CH <sub>3</sub>
14	39.7	39.7	C		29	31.8	31.8	CH <sub>3</sub>
15	30.6	30.6	CH <sub>2</sub>		30	35.0	35.0	CH <sub>3</sub>

<sup>d</sup>Assignments according to Aragao *et al.*, 1990.

## CHAPTER 5

### 5.0 CONCLUSION AND RECCOMENDATIONS

#### 5.1 Conclusion

Both the leaves of *M. pyrifolia* and *T. grandifolia* exhibited *in vitro* anti-plasmodial activity. The methanol extracts were the most active in both plants. However, their clinical

effect may not entirely be due to the anti-plasmodial activity exhibited. Since traditional healers give their medicine as concoction, the effect can also be attributed to the activity of the other plant constituents present in the mixture. Compounds isolated from methanol extract of *M. pyrifolia* had lower *in vitro* anti-plasmodial activity than the crude extract. This suggests that activity in crude extracts may be due to synergistic or additive effects of different compounds therein.

Compounds TGC2 (**61**) a phenolic glycoside, TG 4 (**62**) and TGP 33 (**63**) both pentacyclic triterpenes were isolated from *T. grandifolia* whereas compound MP 24 (**64**) a triterpene was isolated from *M. pyrifolia*. Of all the compounds isolated and characterized, Idesin [6-hydroxy-2-(hydroxymethyl)phenyl  $\beta$ -D-glucopyranoside] TGC2 (**61**) had a higher anti-plasmodial activity D6 ( $IC_{50}$   $9.78 \pm 3.2$   $\mu$ g/ml) and W2 ( $14.4 \pm 1.35$   $\mu$ g/ml). Compounds MPC1, D6 ( $IC_{50}$   $19.45 \pm 2.17$   $\mu$ g/ml) and W2 ( $29.31.4 \pm 1.91$   $\mu$ g/ml), MPC2, D6 ( $IC_{50}$   $27.11 \pm 1.18$   $\mu$ g/ml) and W2 ( $24.22 \pm 2.51$   $\mu$ g/ml) and MPC3, D6 ( $IC_{50}$   $11.12 \pm 2.31$   $\mu$ g/ml) and W2 ( $24.17.4 \pm 6.09$   $\mu$ g/ml) isolated from the methanol extracts of *M. pyrifolia*, had their anti-plasmodial assay  $IC_{50} > 10$   $\mu$ g/ml. Thus they were considered as inactive principles in this plant. Crude extracts were tested for cytotoxicity and they had  $CC_{50} > 20$   $\mu$ g/ml implying that they are not toxic.

## 5.2 Recommendations

It is recommended that:

- *In vivo* anti-malarial studies be carried out on the extracts and compound TGC2 (61). Those found to be active could be followed up for drug development.
- Further drug interaction studies should be done on crude methanol extracts of both *T. grandifolia* and *M. pyrifolia* to establish their potential effects.
- Further fractionation should be carried out on *M. pyrifolia* with the aim of isolating and identifying the active principle(s).
- Acute and chronic toxicity studies to be carried out on the active crude extracts to establish their safety for use in humans. This will help to determine the safety dosage required for parasite clearance.
- Other plant parts such as stem and root bark of *T. grandifolia* be investigated for anti-plasmodial activity and if found to be active, then isolation of the bioactive principles can be carried out with the aim of anti-malarial drug development.

## REFERENCES

- Abe, I.; Rohmer, M.; Prestwich, G. D. (1993) Enzymatic cyclisation of squalene and oxidosqualene to sterols and triterpenes. *Chemical Review*. **93**: 2189-2206.
- Abisch, E.; and Reichstein, T. (1960). Terpenoids. *Helvetica Chimica Acta*. **43**: 1844-1861.
- Adou, E. (2005). Isolation and Characterization of bioactive compounds from Suriname and Madagascar and a Synthetic Approach to Lucilactaene. PhD dissertation, Virginia Polytechnic Institute and State University, USA.



- Akendengue, B.; Ngou-Milama, E.; Laurens, A. and Hocquemiller, R. (1999). Recent advances in the fight against leishmaniasis with natural products. *Parasite* **6**: 3 - 8.
- Alam, M. S.; Chopra, N.; Ali, M. and Niwa, M. (1996). Oleanone and stigmasterol derivatives from *Ambroma augusta*. *Phytochemistry*. **41**: 1197 – 1200.
- Alonso, P. L.; Sarcalal, J.; Aponte, J. J.; Leach, A.; Macete, E.; Milman, J.; Mandomando, I.; Spiessens, B.; Guinovart, C.; Espasa, M.; Bassat, Q.; Aide, P.; Ofori-Anyinam, O.; Navia, M. M.; Corachan, S.; Ceuppens, M.; Dubois, M. C.; Demoitie, M. A.; Dubovsky, F.; Menendez, C.; Torniepoth, N.; Ballou, W. R.; Thompson, R. and Cohen, J. (2004). The efficacy of the RTS,S/ASO2A vaccine against *Plasmodium falciparum* infection and disease in young African children: randomised control trial. *Lancet*. **364**: 1411 – 20.
- Anderson, M. M.; O'Neill, M. J.; Phillipson, J. D. and Warhurst, D. C. (1991). *In vitro* cytotoxicity of a series of quassinoids from *Brucea javanica* fruits against KB cells. *Planta Medica*. **57**:62 - 74.
- Angerhofer, C. K.; Guinaudeau, H.; Wongpanich, V.; Pezzuto, J. M. and Cordell, G. A. (1999). Anti-plasmodial and cytotoxic activity of natural bisbenzylisoquinoline alkaloids. *Journal of Natural Products*. **62**: 59 - 66.
- Appleton, R. A. and Enzell, C. R. (1971). Triterpenoids and Aromatic components of Deer Tongue Leaf. *Phytochemistry*. **10**: 447 - 9.
- Aragao, A. G. M.; Viana, C. F. G. Jr.; Ribeiro, R. A.; Magalhaes, J. F. G.; Vale, M. R. (1990). Effects of *Ageratum conyzoides* in nociception and inflammatory response induced by Zymosan. *Fitoterapia*. **61**: 349–354.
- Arnot, D. (2005). Malaria vaccines. Research problems and priorities. *Scientific review articles*.
- Badam, L., Deolankar, R. P., Kulkarni, M. M., Nagsampgi, B. A., Wagh, U. V. (1987). *In vitro* anti-malarial activity of neem tree (*Azadirachta indica* A. Juss) leaf and seed extracts. *Indian Journal of Malariology*. **24**: 111-7.
- Basco, L. K. and Le Bras, J. (1992). *In vitro* activity of halofantrine and its relationship to other standard anti-malarial drugs against African isolates and clones of *P. falciparum*. *American Journal of Tropical Medicine and Hygiene* **47**: 521 - 27.
- Bennett, J. W. and Chung, K. T. (2001). Alexander Fleming and the discovery of Penicillin. *Advanced Applied Microbiology*. **49**: 163 - 84.

- Bentley, M. D.; Brackett, S. R. and Chappya, A. (1984). 2-hydroxyacetophenone; Principal root volatile of the East African medicinal plant, *Carissa edulis*. *Journal of Natural Products*. **47**(6): 1056 - 7.
- Benyhe, S. (1994). Morphine: New aspects in the study of an ancient compound. *Life Science*. **55**: 969 - 79.
- Berenbaum, M. C. (1978). A method for testing for synergy with any number of agents. *Journal of Infectious Diseases*. **137**(2): 122 - 30.
- Berman, A.; Shearing, L. N.; Ng, K. F.; Jinsart, W.; Foley, M. and Tilley, L. (1994). Photoaffinity labeling of *P. falciparum* proteins involved in Phospholipid transport. *Molecular Biochemistry and Parasitology*. **67**(2): 235 - 43.
- Beutler, J. A.; McCall, K. L.; Herbert, K.; Herald, D. L.; Rettit, G. R.; Johnson, T.; Shoemaker, R. H. and Boyd, M. R. (2000). Novel cytotoxic diterpenes from *Casearia arborea*. *Journal of Natural Products*. **63**: 657 - 9.
- Bezabih, M.; Abegaz, M.; Dufall, K.; Croft, K.; Skinner-Adams, T. and Davis, T. M. E. (2001). Anti-plasmodial and Anti-oxidant Isofuranonaphthoquinones from the Roots of *Bulbine capitata*. *Planta Medica*. **67**: 340 - 44.
- Bodeker, G. and Wilcox, M. L. (2000). Conference report: the first international meeting of the Research Initiative on Traditional Anti-malarial Methods (RITAM). *Journal of Alternative Complimentary Medicine*. **6**: 195 - 207.
- Bojang, K. A.; Milligan, P. J.; Pinder, M.; Vigneron, L.; Allouche, A.; Kester, K. E.; Ballou, W. R.; Conway, D. J.; Reece, W. H.; Gothard, P.; Yamuah, L.; Delchambre, M.; Voss, G.; Greenwood, B. M.; Hill, A.; McAdam, K. P.; Tornierporth, N.; Cohen, J. D. and Doherty, T. (2001). Efficacy of RTS,S/AS02 malaria vaccine against *Plasmodium falciparum* infection in semi-immune adult men in the Gambia: a randomized trial. *Lancet* **358**:1927 - 34.
- Bolzani, V. S.; Trevisan, L. M. V. and Young, M. C. M. (1991). Caffeic acid esters and triterpenes of *Alibertia macrophylla*. *Phytochemistry*. **30**(6): 2089 - 91.
- Bringmann, G.; Saeb, W.; Assi, L. A.; François, G.; Sankara-Narayanan, A. S.; Peters, K. and Peters, E. M. (1997). Betulinic acid: isolation from *Triphyophyllum peltatum* and *Ancistrocladus heyneanus*, anti-malarial activity, and crystal structure of the benzyl ester. *Planta Medica*. **63**: 255 - 7.
- Bringmann, G.; Menche, D.; Bezabih, M.; Abegaz, B. M. and Kaminsky, R. (1999). Anti-plasmodial activity of Knipholone and Related Natural Phenylanthraquinones. *Planta Medica*. **65**: 757 - 8.

- Campbell, C. C. (1997). Malaria: an emerging and re-emerging global plague. *FEMS Immunology and Medical Microbiology*. **18**: 325 - 31.
- Canfield, C. J.; Pudney, M. and Gufferidge, W. E. (1995). Interactions of atovaquone with other anti-malarial drugs against *P. falciparum* *in vitro*. *Experimental Parasitology*. **80**: 373 - 81.
- Carter, R. and Kamini, N. M. (2002). Evolutionary and historical aspects of the burden of malaria; American Society for Microbiology. *Clinical Microbiology Reviews*. **15** : 564 – 594.
- Castro, V. A.; Garcia, C. J.; Gonzalez, A. G.; Hernandez, R.; Suarez, E. (1980). A 3,4 seco triterpene from *Caralluma buchardii*. *Phytochemistry*. **19**: 2210 – 2212.
- Chawira, A. N.; Warhust, D. C.; Robinson, B. L. and Peters, W. (1987). The effect of combinations of qinghaosu (artemisinin) with standard anti-malarial drugs in the suppressive treatment of malaria in mice. *Transactions Of the Royal Society Of Tropical Medicine and Hygiene*. **81**: 554 – 8.
- Chen, M.; Theander, T. G.; Christensen, S. B.; Hviid, L. and Zhail, K. A. (1994). Licochalcone A, a new anti-malarial agent, inhibits *in vitro* of the human malaria parasite *Plasmodium falciparum* and protects mice from *P. yoelii* infection. *Antimicrobial Agents Chemotherapy*. **38**: 1470 - 1475.
- Chhabra, S. C ; Uiso, F. C. and Mshiu, E. N (1984). Phytochemical screening of Tanzanian medicinal plants. *Journal of Ethnopharmacology*. **11**: 157 - 179.
- Chou, C. J.; Lin, L. C.; Tsai, W. J.; Hsu, S. Y. and HoL, K. (1997). Phenyl  $\beta$ -D-Glucopyranoside derivatives from the Fruits of *Idesia polycarpa*. *Journal of Natural Products*. **60**: 375 - 7.
- Churchill, F. C.; Patchen, L. C.; Campbell, C. C.; Schwartz, I. K.; Nguyen-Dinh, P. and Dickinson, C. M. (1985). Amodiaquine as a pro-drug: importance of metabolite(s) in the anti-malarial effect of amodiaquine in humans. *Life Science*. **36**: 53-62.
- Collins, D. J.; Culvenor, C. C. J.; Lamberton, J. A.; Loder, J. W. and Price, J. R. (1990). Plants for medicines. CSIRO Publications, Victoria, Australia, p. 42.
- Connolly, J. D. (1972). *In: Chemistry of Terpenes and Terpenoids*, Ed. Newmann A.A., Academic Press, London, p. 207.

- Conolly, J. D. and Hill, R.A. (1994). Dictionary of Natural Products. Chapman and Hall, p. 4506.
- Curtis, J. (2000). Chloroproguanil-diaspore. *Current Opinion in Anti-infective Investigational Drugs*. (2): 99 - 102.
- Dagne, E. and Steglich, W. (1984). Knipholones: a unique anthraquinone derivative from *Kniphofia foliosa*. *Phytochemistry*. **23**: 1729 - 31.
- Decosterd, L. A.; Hoffmann, E.; Kyburz, R.; Bray, D. and Hostettmann, K. (1991). A new phloroglucinol derivative from *Hypericum calycinum* with anti-fungal and *in vitro* anti-malarial activity. *Planta Medica*. **57**: 548 - 51.
- Desjardins, R. E.; Canfield, C. J.; Haynes, J. D. and Chulay, J. D. (1979). Qualitative assessment of anti-malarial activity *in vitro* by a semi-automated micro-dilution technique. *Antimicrobial Agents Chemotherapy*. **16**: 710 - 5.
- Desnerves, J.; Thom, G.; Berman, A.; Galatis, D.; La Greca, N.; Sinding, J.; Foley, M.; Deady, L. W.; Cowman, A. F. and Tilley, L. (1996). Photo affinity labeling of mefloquine-binding proteins in human serum, uninfected erythrocytes and *Plasmodium falciparum* - infected erythrocytes. *Molecular and Biochemical Parasitology*. **82**: 181 - 94.
- Dey, P. M. and Harborne, J. B. (1991). *In: Methods in plant biochemistry*. Harborne, J.B (Ed); Academic Press Inc: San Diego, Volume 6: Assays for bioactivity. Pp 71 - 133.
- Dev, V.; Hira, C. R. and Rajkkhowa, M. K. (2001). Malaria-attributable morbidity in Assam, north-eastern India. *Annals of Tropical Medicine and Parasitology*. **95**: 789 - 96.
- Doherty, J. F.; Pinder, M.; Torniporth, N.; Carton, C.; Vigneron, L.; Milligan, P.; Ballou, W. R.; Holland, C. A.; Kester, K. E.; Voss, G.; Momin, P.; Greenwood, B. M.; Mc Adam, K. P. and Cohen, J. (1999). A phase I safety and immunogenicity trial with candidate malaria vaccine RTS,S/SBAS2 in semi-immune adults in the Gambia. *American Journal of Tropical Medicine and Hygiene*. **61**: 865 - 8.
- Dutta, G. P. (1995). Challenges of drug resistance reversal in malaria. *Journal of Parasitic Diseases*. **19**: 5 - 8.
- Ekong, R.; Partridge, S. J.; Anderson, M. M.; Kiby, G. C.; Warhust, D. C.; Russel, P. F. and Phillipson, J. D. (1991). *Plasmodium falciparum* effects of Phaeanthine, a Naturally Occuring Bisbenzylisoquinoline Alkaloid, on Chloroquine-Resistant and Chloroquine-Sensitive Parasites *in Vitro*, and its Influence on Chloroquine Activity. *Transactions of the Royal Society of Tropical Medicine and Hygiene*. **80**: 742 - 53.

- Ekweozor, C.; Aderounmu A. F. and Sodeinde O. (1987). Comparison of the relative *in vitro* activity of chloroquine and amodiaquine against chloroquine sensitive strains of *P. falciparum*. *Annals of Tropical Medicine and Parasitology*. **81**: 95 – 9.
- Egan, T. J. and Marques H. M. (1999). The role of haem in the activity of chloroquine and related anti-malarial drugs. *Coordination Chemistry Reviews*. **190-192**: 493 - 4.
- Elford, B. C.; Roberts, M. F.; Phillipson, J. D. and Wilson, R. J. (1987). Potentiation of the anti-malarial activity of qinghaosu by methoxylated flavones. *Transactions of the Royal Society of Tropical Medicine and Hygiene*. **81**: 434 - 6.
- Elueze, E. I.; Croft, S. L. and Warhurst, D. C. (1996). Activity of pyronaridine and mepacrine against twelve strains of *Plasmodium falciparum* isolates *in vitro*. *Journal of Antimicrobial Chemotherapy*. **37**: 511 - 8.
- Fivelman, Q. L.; Walden, J. C.; Smith, P. J.; Folb, P. I. and Barnes, K. I. (1999). The effect of artesunate combined with standard anti-malarials against chloroquine sensitive and chloroquine resistant strains of *Plasmodium falciparum* *in vitro*. *Transactions of the Royal Society of Tropical Medicine and Hygiene*. **93**: 429 - 32.
- Floyd, A. G. (1989). Rainforest trees of Mainland South-eastern Australia. Forestry Commission of New South Wales, Inkata Press, Sydney, p. 160.
- Fournet, A.; Barrios, A. A.; Munoz, V.; Hocquemiller, R. and Cave, A. (1992). Effect of natural naphthaquinones in BAB/c mice infected with *Leishmania amazonensis* and *L. venezuelensis*. *Tropical Medical Parasitology*. **43**: 219 - 22.
- Fournet, A. and Muñoz, V. (2002). Natural products as Trypanocidal, Anti-leishmanial and Anti-malarial Drugs. *Current Topics in Medicinal Chemistry*. **2**: 1215 - 37.
- Foye, W. U. (1974). Parasite Chemotherapy: Principles of Medicinal Chemistry. 2<sup>nd</sup> Edition. Henry Kimpton Publishers, London. Great Britain. pp 398 – 400.
- Francis, S. E.; Sullivan, D. J. and Goldberg, D. E. (1997). Haemoglobin metabolism in the malaria parasite *Plasmodium falciparum*. *Annual Review of Microbiology*. **51**: 97 - 123.
- François, G.; Timperman, G.; Elling, W.; Assil, A.; Holenz, J. and Bringmann, G. (1997). Naphthylisoquinoline alkaloids against: evaluation of the curative potentials of dioncophylline C and dioncopeltine A against *P. berghei* *in vivo*. *Antimicrobial Agents and Chemotherapy*. **41**: 2533 - 39.
- Francois, G.; Timperman, G.; Hoenz, J.; Aké Assi, L.; Geuder, T.; Maes, L.; Dubois, J.; Hanocq, M. and Bringmann, G. (1994). Naphthylisoquinoline Alkaloids Exhibit Strong Growth-Inhibiting Activities against *Plasmodium falciparum* and *P. berghei* *in Vitro*.

Structure-Activity Relationships of Dioncophylline C. *Annals of Tropical Medicine and Parasitology*. **90**: 115 - 23.

Fraquinho, L. (1994). Madeira: Plants and Flowers. p 243.

Gachathi, F. N. (1989). Kikuyu *Botanical Dictionary of Plant Names and Uses*. AMREF Printing Department, Nairobi.

Gakunju, D. N. M.; Mberu, E. K.; Dossaji, S. F.; Gray, A. I.; Waigh, R. D.; Waterman, P. G. and Watkins, W. M. (1995). Potent anti-malarial activity of the alkaloid nitidine, isolated from a Kenyan herbal remedy. *Antimicrobial Agents and Chemotherapy*. **39**: 2606 - 9.

Goodwin, T. W. (1981). *In: Biosynthesis of Isoprenoid Compounds*, Ed. Porter J.W., Wiley, New York, Vol. 1, p. 443.

Goodwin, T. W.; Mercer, E. I. (1983). Introduction to plant biochemistry. Second Edition. Pergamon Press, Oxford, England.

Grellier, P.; Rigomier, D.; Clavey, V.; Fruchart, J. C. and Schrevel, J. (1991). Lipid traffic between high density lipoproteins and *P. falciparum*-infected blood cells. *Journal of Cell Biology*. **112**: 267 - 77.

Grellier, P.; Ramiarmanana, L.; Millerioux, V.; Deharo, E.; Schrevel, J.; Frappier, F.; Trigalo, F.; Bodo, B.; and Pousset, J-L. (1996). Anti-malarial activity of cryptolepine and isocryptolepine, alkaloids isolated from *Cryptolepis sanguinolenta*. *Phytotherapy Research*. **10**: 317 - 21.

Grellier, P.; Zirihi, G. N.; Mambu, L.; Guede-Guina, F. and Bodo, B. (2005). *In vitro* anti-plasmodial activity and cytotoxicity of 33 West African plants used for treatment of malaria. *Journal of Ethnopharmacology*. **98**: 281 - 5.

Gu, Z. P.; Zhang, S. M.; Wang, C. L.; Lian, W. Y.; Xiao, P. G. and Chen, J .M. (1997). Determination of strychnine and brucine in *Strychnos* by HPLC. *Yao Xue Xue Bao*. **32**: 791 - 4.

Guerin, P. J. (2002). Malaria: Current status of control, diagnosis, treatment and a proposed agenda for research and development. *Lancet Infectious Diseases*. **2**: 564 – 67.

Gupta, S.; Thapar, M. M.; Wernsdorfer, W. H. and Björkman, A. (2002). *In vitro* interactions of artemisinin with atovaquone, quinine, and mefloquine against *Plasmodium falciparum*. *Antimicrobial Agents and Chemotherapy*. **46**: 1510 - 5.

- Habib, M. R.; Nikkon, F.; Rahman, M.; Haque, M. E.; Karim, M. R. (2007). Isolation of stigmaterol and  $\beta$ -sitosterol from methanolic extract of root bark of *Calotropis gigantea* (Linn). *Pakistan Journal of Biological Sciences*. **10**: 4174 - 4176.
- Harborne, J. B. and Herbert, B. (1993). *Phytochemical Dictionary. A Handbook of Bioactive Compounds from plants*. Taylor and Francis Ltd, London.
- Harborne, J. B. (1994). "Biochemistry of Phenolic Compounds". Academic Press, London.
- Hazra, B.; Gosh, R.; Banerjee, A.; Kirby, G. C.; Warhurst, D. C. and Philipson, J. D. (1995). *In vitro* anti-plasmodial effects of diospyrin, a plant derived naphthoquinoid, and a novel series of derivatives. *Phytotherapy Research*. **9**: 72 - 4.
- Hedberg, I.; Hedberg, O.; Madati, P. J.; Mshigeni, K. E.; Mshiu, E. N. and Samuelsson, G. (1983). Inventory of plants used in traditional medicine in Tanzania: plants of the families Dilleniaceae-Opiliaceae. *Journal of Ethnopharmacology*. **9**(1): 105 - 127.
- Hegnauer, R. (1966). *Chemotaxonomie der Pflanzen*. Birkhauser, Band 4, Birkhauser Verlag, Basel and Stuttgart, Germany, p. 155.
- Hocquemiller, R.; Cortes, D.; Arago, G. J.; Myint, S. H. and Cavé, A. (1991). Isolation and synthesis of espintanol, a new anti-parasitic monoterpene. *Journal of Natural Products*. **54**: 445 - 452.
- Hoffman, S. L. and Miller, L. H. (1996). Perspectives on malaria vaccine development. In: Hoffman, S. L., editor. *Malaria vaccine development*. Washington: ASM Press; 1 - 13.
- [Http://eanmat.org/www.tmacipac.mahidol.ac.th/home/gpcci.html](http://eanmat.org/www.tmacipac.mahidol.ac.th/home/gpcci.html) accessed on 3 August, 2006.
- Jain, M.; Vangapandu, S.; Sachdeva, S.; Singh, S.; Singh, P. P.; Jena, G. B.; Tikoo, K.; Ramarao, P.; Kaul, C. L. and Jain, R. (2004). Discovery of a Bulky 2-tert-Butyl Group containing Primaquine Analogue Exhibits Potent Blood – Schizontocidal Antimalarial Activities and Complete Elimination of Methemoglobin Toxicity. *Journal of Medicinal Chemistry*. **47**: 285- 287.
- Jacquemond-Collet, I.; Benoit-Vical, F.; Mustofa, V. A.; Stanislas, E.; Mallie, M. and Fourastie, I. (2002). Anti-plasmodial and Cytotoxic Activity of Galipinine and other Tetrahydroquinolines from *Gallipea officinalis*. *PlantaMedica*. **68**: 68 - 69.
- Kaendi, J. M. (1994). Coping with Malaria and Visceral Leishmaniasis (Kala-azar) in Baringo District, Kenya: Implications for Disease Control. *Ph.D. Thesis*, University of California, Los Angeles.

- Kannan, R.; Sahal, D. and Chauhan, V. S. (2002). Heme-artemisinin adducts are crucial mediators of the ability of artemisinin to inhibit heme polymerization. *Chemistry and Biology*. **9**: 321 - 32.
- Kayser, O.; Kiderlen, A. F. and Croft, S. L. (1998). In : *Proceedings of the 9<sup>th</sup> International Congress of parasitology*, Monduzzi Editore: Bologna, Italy, p 195 - 202.
- Kayser, O.; Brun, R. and Kiderlen, A. F. (2001). *In vitro* activity of aurones against *P. falciparum* strains NF1 and K54. *Planta Medica*. **67**: 718 - 21.
- Kayser, O.; Kiderlen, A. F. And Croft, S. L. (2003). Natural products as anti-parasitic drugs. *Parasitology Research*. **90**: S55 - S62.
- Kim, S. H.; Jang, Y. P.; Sung, S. H. and Kim, Y. P. (2006). Glycosides from the fruits of *Idesia polycarpa* on lipopolysaccharide-induced nitric oxide production in BV2 microglia. *Planta Medica*. **72**: 167 - 9.
- Khalid, S.A., Duddeck, H., Gonzalez-Sierra, M. (1989). Isolation and characterization of an anti-malarial agent of the neem tree *Azadirachta indica*. *Journal of Natural Products*. **52**. 922-6.
- Kholer, I.; Kristina, J.; Kraft, C.; Karsten, S.; Abbiw, D.; Bienzler, E. and Eckart, E. (2002). Herbal Remedies Traditionally Used Against Malaria in Ghana: Bioassay Guided Fractionation of *M. pyrifolia* (Asteraceae). *Zeitschrift für Naturforschung* . **57c**: 1022 - 1027.
- Kirby, G. C.; Paine, A.; Warhust, D. C.; Noamese, B. K. and Philipson, J. D. (1995). *In vitro* and *In vivo* anti-malarial activity of cryptolepine, a plant derivative indolquinoline. *Phytotherapy Research*. **9**: 359 - 63.
- Kirira, P. G (2004). Chemical and Biological Studies of selected plants from Meru and Kilifi Districts. *MSc. Thesis*, Kenyatta University, Kenya.
- Kofi-Tsekpo, W. M.; Rukunga, G. M.; Aluoch, J. A.; Khan, B.; Wayiaki, P. G.; Tolo, F. and Muthotho, N. (1989). A preliminary investigation of a traditional medicine (KRM 913) as a potential anti-malarial and anti-parasitic agent. Proceedings of the 10<sup>th</sup> annual Medical Scientific Conference. KEMRI-KETRI, p352-355.
- Kokwaro, J. O. (1993). Medicinal Plants of East Africa, 3<sup>rd</sup> Ed. ; Kenya Literature Bureau. Nairobi.
- Kremsner, D. G.; Looaresuwan, S. and Chulay, J. D. (1999). Atovaquone and proguanil hydrochloride for the treatment of malaria. *Journal of Travel Medicine*. **6**: 518 - 20.



Kuehne, M. E. and Xu, F. (1997). Synthesis of strychnan and aspidosperma-type alkaloids. The enantioselective generation of tetracyclic ABCE intermediates by a tandem condensation, [3,3]-sigmatropic rearrangement, and cyclization sequence. *Journal of Organic Chemistry*. **62**: 7950 - 60.

Le Bras, J. and Deloron, P. (1983). *In vitro* study of drug sensitivity of *Plasmodium falciparum*: An evaluation of a new semi-microtest. *American Journal of Tropical Medicine and Hygiene*. **32**: 447 - 51.

Li, G. Q.; Peggins, J. O.; Lin, A. J. and Masonic, K. J. (1989). Clinical studies on artemisinin suppository and or artesunate and artemether. In Shen JX (ed) *Anti-malarial Drug Development in China*. Beijing: *National Institute of Pharmaceutical Research and Development*: 69 – 73.

Li, R.; Kenyon, G. L.; Cohen, F. E.; Chen, X.; Gong, B.; Dominguez, J. N.; Davidson, E.; Kurzban, G.; Miller, G. E.; Nuzum, E. O.; Rosenthal, P. J. and McKerrow, J. H. (1995). *In vitro* anti-malarial activity of chalcones and their derivatives. *Journal of Medicinal Chemistry*. **38**: 5031 - 7.

Likhitwitayawuid, K.; Phadungcharoen, T. and Krungkrai, J. (1998). Anti-malarial xanthenes from *Garcinia cowa*. *Planta Medica*. **64**: 70 - 2.

Lima, R. A.; Gottlieb, O. R. and Mesquita, A. A. L. (1972). The chemistry of Brazilian Guttiferae. XXVIII. Xanthanones from *Caraipa densiflora*. *Phytochemistry*. **11**(7): 2307 - 9.

Lin, A. J.; Klayman, D. L. and Milhous, W. K. (1993). Anti-malarial activity of new water soluble dihydroartemisinin derivatives. *Journal of Medicinal Chemistry*. **30**: 2147 - 50.

Looareesuwan, S.; Viravan, C.; Webster, H. K.; Kyle, D. E.; Hutchinson, D. B. and Canfield, C. J. (1996). Clinical studies of atovaquone, alone or in combination with other anti-malarial drugs, for treatment of acute uncomplicated malaria in Thailand. *American Journal of Tropical Medicine and Hygiene*. **54**: 62 - 6.

López-Pérez, J. L.; Therón, R.; Del Olmo, E.; Díaz, D. (2007). NAPROC-13: a database for the dereplication of natural product mixtures in bioassay-guided protocols. *Bioinformatics*. **23**: 3256-3257.

Luke, T. C. and Hoffman, S. L. (2003). Rationale and plans for developing a non-replicating, metabolically active, radiation-attenuated *Plasmodium falciparum* sporozoite vaccine. *Journal of Experimental Biology*. **206**: 3803 – 8 .

- Madrid, P. B.; Sherrill-Liou, A. P.; Weisman, J. L.; Derisi, J. L. and Guy, R. K. (2005). Synthesis of Ring – Substituted 4- aminoquinolines and Evaluation of their Anti-malarial Activities. *Bioorganic and Medicinal Chemistry*. **15**: 301 - 22.
- Majester-Savornia, B.; Elias, R.; Diaz-Lanza, A. M.; Balansard, G.; Gasquet, M. and Delmas, F. (1991). Saponins of the ivy plant, *Hedera helix*, and their leishmanicidal activity. *Planta Medica*. **57**: 260 - 2.
- Malakooti, M. A.; Biomndo, K. and Shanks, G. D. (1998). Re-emergence of epidemic malaria in the highlands of western Kenya. *Emerging Infectious Diseases*. **4**: 671 - 6.
- Meyer, B. N.; Ferrigni, N. R.; Jeptunan, L. B.; Jacobsen, N. D. E. and McLaughlin, J. L. (1982). Brine shrimp lethality bioassay method. *Planta Medica* **45**: 31 - 4.
- Moretti, C.; Deharo, E.; Sauvain, M.; Jardel, C.; David, P. T. and Gasquet, M. (1994). Anti-malarial activity of Cedronin. *Journal of Ethnopharmacology*. **43**: 57 - 61.
- Mosmann, T. (1983). Rapid colometric assay for cellular growth and survival: application to proliferation and cytotoxicity assays. *Journal of Immunological Methods*. **65**: 55 - 63.
- Moudachirou, M.; Ayedoun, M. A.; Gbenou, J. D.; Garneau, F. X.; Gagnon, H. and Jean, F. (1998). Essential oil of *Carissa edulis* Vahl. From Benin. *Journal of Essential Oil Research*. **10**: 195 - 6.
- Muregi, F. W.; Chhabra, S. C.; Njagi, E. N. M.; Langa't-Thoruwa, C. C.; Omar, S. A. and Ndiege, I. O. (2003). *In vitro* anti-plasmodial activity of some plants used in Kisii, Kenya against malaria and their chloroquine potentiating effects. *Journal of Ethnopharmacology*. **84**: 235 - 9.
- Muthaura, C. N.; Rukunga, G. M.; Chhabra, S. C.; Mungai, G. M. and Njagi, E. N. M. (2007). Antimalarial activity of some plants traditionally used in treatment of malaria in Kwale district of Kenya. *Journal of Ethnopharmacology*. **112**: 545 – 51.
- Mwagiru, P. M. (2005). Fundamentals of Pharmaceutical Chemistry. Solutions for Science Publishers. Nairobi. 232 – 239.
- Nkunya, M. H. H. (2002). Natural Chemicals for Disease and Insect Management. Professional Inaugural Lecture. University of Dar-es-Salaam. 93 - 101.
- Nussenzweig, R. S. and Nardin, E. H. (1993). T-Cell responses to pre-erthrocytic stages of malaria: role in protection and vaccine development against pre-erthrocytic stages. *Annual Reviews in Immunology*. **11**: 687 – 727.

- Ogutu, B. R.; Smoak, B. L.; Nduati, R. W.; Mbori-Ngacha, D. A.; Mwathe, F. and Shanks, D. G. (2000). The efficacy of pyrimethamine sulfadoxine in the treatment of uncomplicated plasmodium malaria in Kenyan children. *Transactions of the Royal Society of Tropical Medicine and Hygiene*. **94**: 83 - 4.
- Oketch-Rabah, H.; Lemmich, E.; Dossaji, S. F.; Theander, T.G.; Olsen, C. E.; Cornett, C.; Kharazmi, A. and Christensen, S. B. (1997). Two new anti-protozoal 5-methylcoumarins from *Vernonia brachycalyx* Hoffm. *Journal of Natural Products*. **60**: 458 - 61.
- Oketch-Rabbah, H. A.; Mwangi, J. W.; Lisgarten, J. and Mberu, E. K. (2000). A new anti-plasmodial coumarin from *Toddalia asiatica* roots. *Filoterapia*. **71**: 636 - 40.
- Oketch-Rabah, H. A.; Mwangi, J. W., Lisgarten, J. and Mberu, E. K. (2001). Anti-malarial activity of some Kenyan medicinal plants. *Fitoterapia*. **71**: 636 - 640.
- Ongore, D.; Kamunvi, F.; Knight, R. and Minawa, A. (1989). A Study of Knowledge, attitudes and practices (KAP) of a Rural Community on Makina and the Mosquito Vector. *East African Medical Journal*. **66**: 79 - 90.
- Pagola, S.; Stephens, P. W.; Bohle, D. S.; Kosar, A. D., Madsen, S. K. (2000). The structure of malaria pigment  $\beta$ -haematin. *Nature*. **404**: 307 - 10.
- Parida, M. M.; Upadhyay, C.; Pandya, G. and Jana, A. M. (2002). Inhibitory potential of neem *Azadirachta indica* Juss leaves on Dengue virus type-2 replication *Journal of Ethnopharmacology*. **79**: 273 - 8.
- Partridge, S. J.; Russell, P. F.; Kirby, G. C.; Warhust, D. C.; Phillipson, J. D.; O'Neill, M. J. and Schiff P. L. (1989). *In vitro* Anti-malarial activity of *Triclisia dictophylla* and some of its constituent. *Journal of Pharmacy and Pharmacology*. **41**: 92.
- Phillipson, J. D. and O'Neill, M. J. (1987). In: *Biologically Active Natural Products*. Hostettman K., Lea P. J. (eds). Clarendon Press, Oxford, p 49-64.
- Phillipson, J. D. and Wright, C. W. (1991). Can ethnopharmacology contribute to the development of anti-malarial agents? *Journal of Ethnopharmacology*. **32**: 155 - 65.
- Phillipson, J.; Wright, C. W.; Kirby, G. C. and Warhust, D.C. (1993). Tropical plants as sources of anti-protozoal agents. In: Downum, K. R.; Romeo, J.R.; Stafford, H.A. (eds) *Phytochemical potential of tropical plants, vol 27. Recent advances in phytochemistry*. Plenum press, New York, pp 1 - 40.
- Picerno, P.; Autore, G.; Marzocco, S.; Meloni, M.; Sanogo, R. and Aquino, R. P. (2005). Anti-inflammatory activity of Verminoside from *Kigelia africana* and Evaluation of

Cutaneous Irritation in Cell Cultures and Reconstituted Human Epidermis. *Journal of Natural Products*. **68**: 1610 - 4.

Polonsky, J. (1985). *Quassinoid Bitter Principles II* Ed Herz W., In progress in the chemistry of Natural Products. Pp 222 - 239.

Radloff, P. D.; Phillips, J.; Nkeyi, M.; Hutchinson, D. and Kremsner P. G. (1996). Atovaquone and proguanil for *Plasmodium falciparum* malaria. *Lancet*. **347**: 1511 - 4.

Rasoanaivo, P. and Rastimamanga-Urveg, S. (1993). *Biological Evaluation of Plants with Reference to Malagasy Flora*. Monograph prepared for the IFS-NAPRECA workshop on bioassays, Antananarivo, Madagascar Pp 1 - 72.

Rayo, C. C. M.; Croft, S. L. and Philipson, J. D. (2000). Natural products as sources of anti-protozoal drugs. *Current Opinion in Anti-Infective Investigational Drugs*. **2**: 47 - 62.

Razden, T. K.; Harkar, S.; Quadri, B.; Quirishi, M. A. and Khuroo, M. A. (1988). Lupene derivatives from *Skimmia laureola*. *Phytochemistry*. **27**: 1890 - 2.

Ribeiro, A.; Pilo-Veloso, D.; Romanha, A. J. and Zani, C. L. (1997). Trypanocidal flavonoids from *Trixis vauthieri*. *Journal of Natural Products*. **60**: 836 - 41.

Robert, A.; Dechy-Cabaret, O.; Cazelles; J. and Meunier, B. (2002). From Mechanistic studies on artemisinin derivatives to new modular anti-malarial drugs. *Accounts of Chemical Research*. **35**: 167 - 74.

Roberts, J. S. (1972). In *Chemistry of Terpenes and Terpenoids*, Ed. Newmann A.A. Academic Press, London, P. 88.

Rochanakij, S., Thebtaranonth Y., Yenjai C., Yuthavong Y. (1985). Nimbolide, a constituent of *Azadirachta indica* inhibits *Plasmodium falciparum* in culture. *S.E. Asian Journal of Tropical Medicine and Public Health*. **16**: 66-72.

Rowe, A. W.; Eyster, E. and Kellner, A. (1968). Liquid nitrogen preservation of blood cells for transfusion. *Cryobiology*. **5**: 119 - 28.

Samaraweera, U., Sotheeswaran, S. and Sultanbawa, M.U.S. (1983). 5,5,3',5'-pentahydroxyflavan and 3 $\alpha$ -methoxy friedelan from *Humboldtia laurifolia*. *Phytochemistry*. **22**: 565-7.

Schuster, B. G. (2001). Demonstrating the validity of natural products as anti-infective drugs. *Journal of Alternative and Complementary Medicine*. 7 Suppl 1:S73 - 82.

- Sepuvelda-Boza, S. and Cassels, B. K. (1996). Plant metabolites active against *Trypanosoma cruzi*. *Planta Medica*. **62**: 98 - 105.
- Shalmiev, G., Krugliak, M., Turrini, F. and Ginsburg, H. (1996). Anti-malarial drugs that inhibit the phagocytosis of erythrocytes infected with *Plasmodium falciparum*. *Transactions of the Royal Society of Tropical Medicine and Hygiene*. **90**: 558 - 62.
- Sharma, S. C. and Agarwal, V. K. (1993). *Brucea javanica* (Linn.) Mer.: A potent anti-cancer and anti-malarial plant-a review. *Indian Journal of Pharmaceutical Science*. **55**: 77 - 85.
- Shoba, F. G. and Thomas, M.(2001). Study of anti-diarrhoeal activity of four medicinal plants in castor-oil induced diarrhea. *Journal of Ethnopharmacology*. **76**: 73 - 6.
- Sixsmith, D. G.; Watkins, W. N.; Chulay, J. D. and Spencer, H. C. (1984). *In vitro* anti-malarial activity of tetrahydrofolate dehydrogenase inhibitors. *American Journal of Tropical Medicine and Hygiene*. **33**:772 - 76.
- Slater, A. F. G.; Swiggard, W. J.; Orton, B. R.; Flitter, W. D.; Goldberg, D. E. Cerami, A. and Henderson, G. B. (1991). On the molecular mechanism of chloroquine's anti-malarial action. *Proceedings of the National Academy of Sciences of USA*. **88**: 325 - 9.
- Snow, R. W.; Craig, M. H.; Deichmann, U. and Le Sueur, D. (1999). A Preliminary Continental Risk Map for Malaria Mortality Among African Children. *Parasitology Today*. **15**: 99 – 104.
- Solis, P. N.; Langa't, C. C.; Gutpa, P. M.; Warhust, D. C. and Philpson, J. D. (1995). A micro-well cytotoxicity assay using *Artemia salina* (brine shrimp). *Planta medica*. **79**: 11 - 3.
- Spencer, C. J.; Koniuszy, F. R.; Rogers, E. F.; Sharel Jr, J.; Easton, N. R.; Kacska, E. A.; Kuehl Jr, F. A.; Phillips, R. F.; Walti, A. and Folkers, K. (1947). Survey of plants for anti-malarial activity. *Llyodia*. **10**: 145 - 52.
- Sudhanshu, S.; Neerja, P.; Jain, D. C. and Bhakuni, R. S. ( 2003). Anti-malarial agents from plant sources. *Current Science*. **85**: 1314 - 1329.
- Sukul, N. C.; De, A.; Dutta, R.; Sukul, A. and Sinhababu, S. P. (2001).Nux vomica 30 prepared with and without succession shows anti-alcoholic effect on toads and distinctive molecular association. *British Homeopathy Journal*. **90**: 79 - 85.
- Tandon, J. S.; Srivastava, V. and Guru P. Y. (1991). Iridoids: a new class of leishmanicidal agents from *Nyctanthes arbortristis*. *Journal of Natural Products*. **54**: 1102 - 4.

Trager, W. and Jensen, J. B. (1976). Human Malaria parasites in continuous culture. *Science*. **193**: 673 - 5.

Vangapandu, S.; Jain, M.; Kaur, K.; Patil, P.; Sanjay, R. P. and Jain, R. (2006). Advances in Anti-malarial Drug Development. *Medicinal Research Reviews*. **27**: 65 - 107.

Van Agtmael, M. A.; Eggelte, T. A. and Van Boxtel, C. J. (1999). Artemisinin drugs in treatment of malaria: from medicinal herb to registered medication. *Trends in Pharmaceutical Sciences*. **20**:199 - 205.

Waterman, P. G. (1996). Screening of some Australian Flacoutiaceae species for *in-vitro* antioxidant, cytotoxic and antimicrobial activity. *Phytomedicine*. **11**: 461 – 466.

Wendt, K. U.; Schulz, G. E., Corey, E. J.; Liu, D. R. (2000). Biomimetic Polyene Cyclizations *Angewandte Chemie International Edition*. **39**, 2812-2833.

Wernsdorfer, W. H. and Trigg, P. I. (1984). Primaquine: Pharmacokinetics, Metabolism, Toxicity and Activity. John Wiley and Sons Publishers, Great Britain.

White, N. J. (2004). Anti-malarial drug resistance. *Journal of Clinical Investigations*. **113**: 1084 – 1092.

WHO (1984). Advances in Malaria Chemotherapy. *WHO Technical Report Series*. Geneva.

WHO (1990). Severe and complicated malaria. *Transactions of the Royal Society of Tropical Medicine and Hygiene*. **8**: 1-65.

WHO (1991). Guidelines for the assessment of herbal medicines, programme on traditional medicine, Geneva (WHO/ TRM/91.4).

WHO (1996). Revised facts on malaria. *Malaria weekly*. **15**: 7-9.

WHO (1998). The Use of Artemisinin & Its Derivatives as Anti-malarial Drugs: Report of a Joint CTD/DMP/TDR Informal Consultation. WHO/MAL/98. 1086.

WHO (2001). Anti-malarial Drug Combination Therapy. Report of Technical Consultation. WHO, Geneva, 4-5 April 2001.

Wild, H. (1975). The compositae of the Flora Zambesiaca area 4. *Kirkia*. **10**:1-72.

Willcox, M. L. and Gerard, B. (2004). Traditional Herbal Medicines for Malaria. *British Medical Journal*. **329**: 1156 – 9.

Wistanley, P.; Watkins, W. M. and Newton, C. R. J. C. (1992). The disposition of oral and intramuscular pyrimethamine/sulphadoxine in Kenyan Children with high parasitemia but chemically non-severe falciparum malaria. *British Journal of Clinical Pharmacology*. **33**: 14 – 148.

[www.kmis.org/Default.htm](http://www.kmis.org/Default.htm), 2002 accessed at 1600 hrs on 3 August, 2006.

[www.who.int/vaccines-documents/](http://www.who.int/vaccines-documents/) accessed at 0930 hrs on 26 July, 2006.

Ye, Z.; Dyke, K. V. and Castranova, V. (1989). The Potentiating Action of Tetrandrine in Combination with Chloroquine or Qinhaosu against Chloroquine-Sensitive and Resistant Falciparum Malaria. *Biochemical and Biophysical Research Communications*. **165**: 758 - 765.

Zirihi, G. N.; Mambu, L.; Guede-Guina, F.; Bodo, B. and Grellier, P. (2005). *In vitro* anti-plasmodial activity and cytotoxicity of 33 West African plants used for treatment of malaria. *Journal of Ethnopharmacology*. **98**: 281 - 5.

**Appendix 1: IR spectrum of Idesin [6-hydro-2-(hydroxymethyl)phenyl  $\beta$ -D-glucopyranoside] (61)**

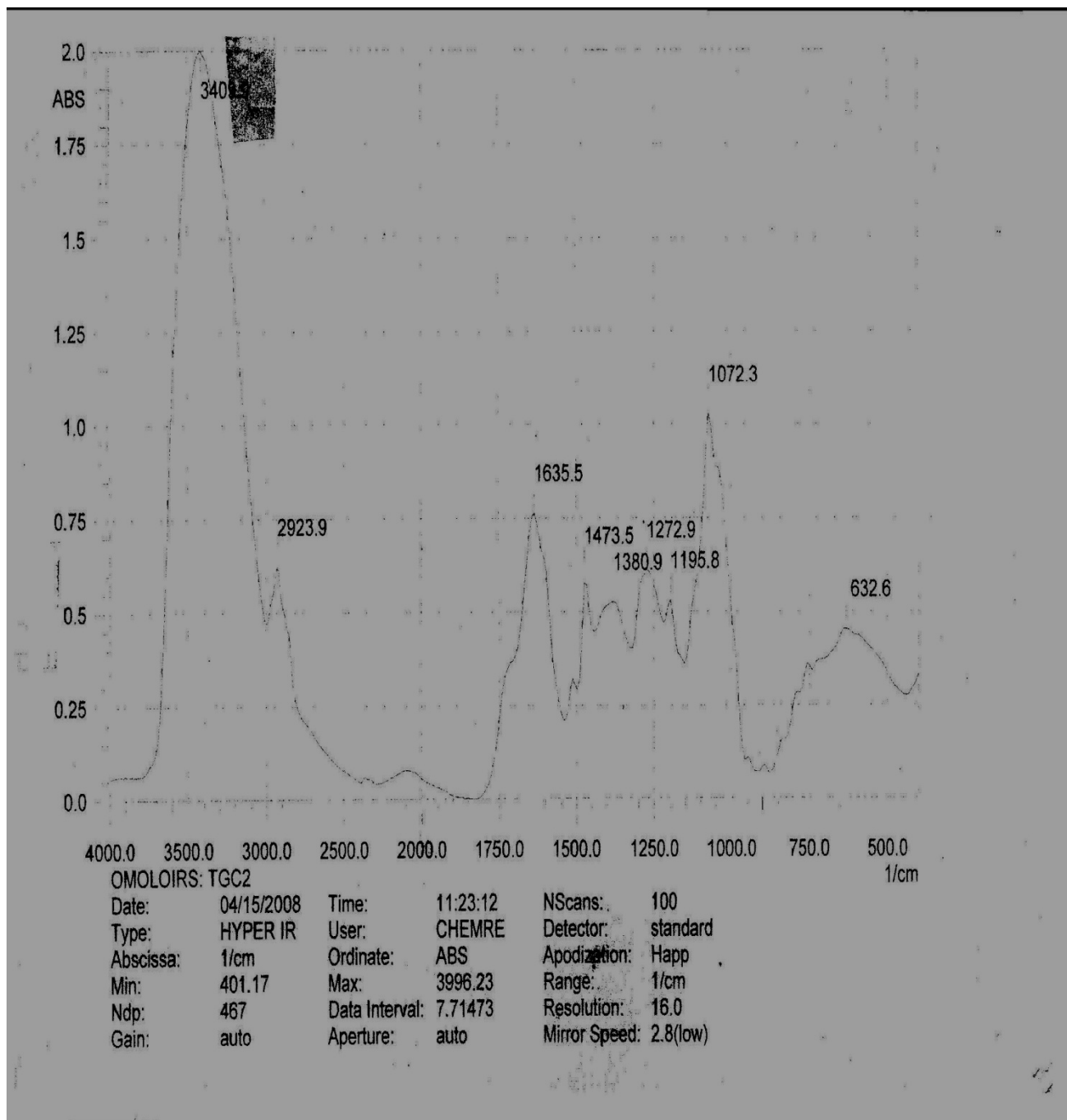

**Appendix 2:  $^1\text{H}$  NMR spectrum of Idesin [6-hydro-2-(hydroxymethyl)phenyl  $\beta$ -D-glucopyranoside] (61)**



Omolo (JKUAT)  
TGC 2  
52.6 mg MeOD  
06-09-2007

Pulse Sequence: s2pul

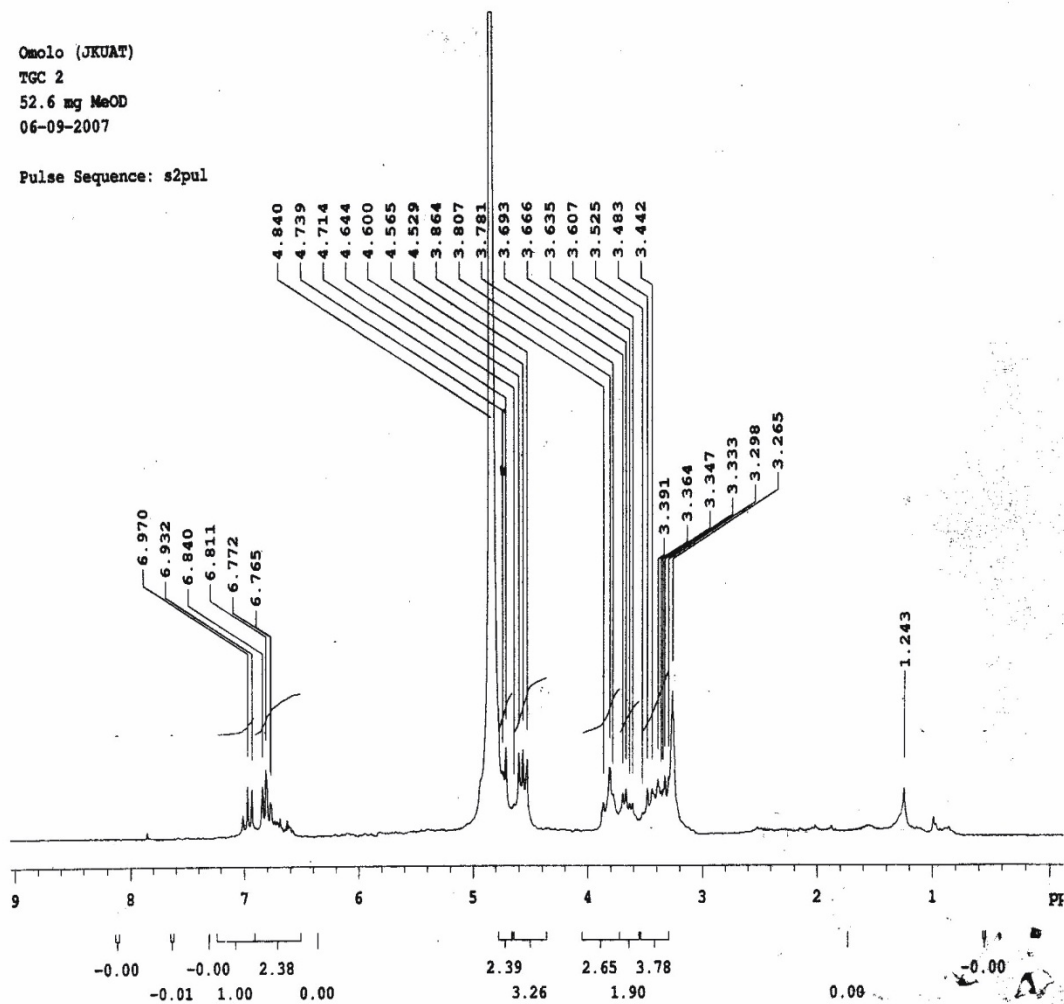

Appendix 3:  $^{13}\text{C}$  NMR spectrum of Idesin [6-hydroxy-2-(hydroxymethyl)phenyl  $\beta$ -D-glucopyranoside] (61)

Omolo (JKUAT)  
TGC 2  
52.6 mg  
MeOD  
06-09-2007

Pulse Sequence: s2pul

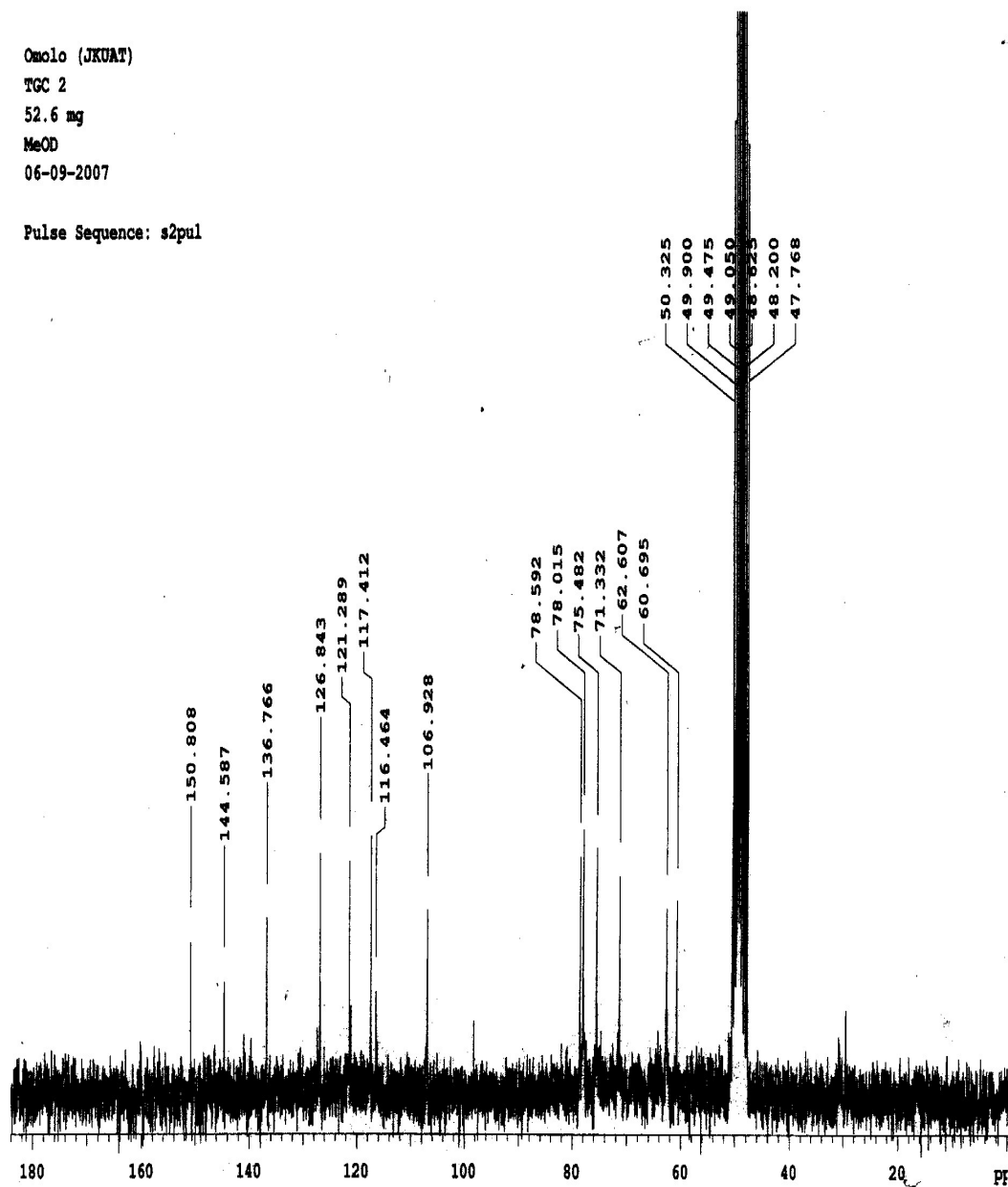

Appendix 4 :DEPT NMR spectrum of Idesin [6-hydro-2-(hydroxymethyl)phenyl  $\beta$ -D-glucopyranoside] (61)

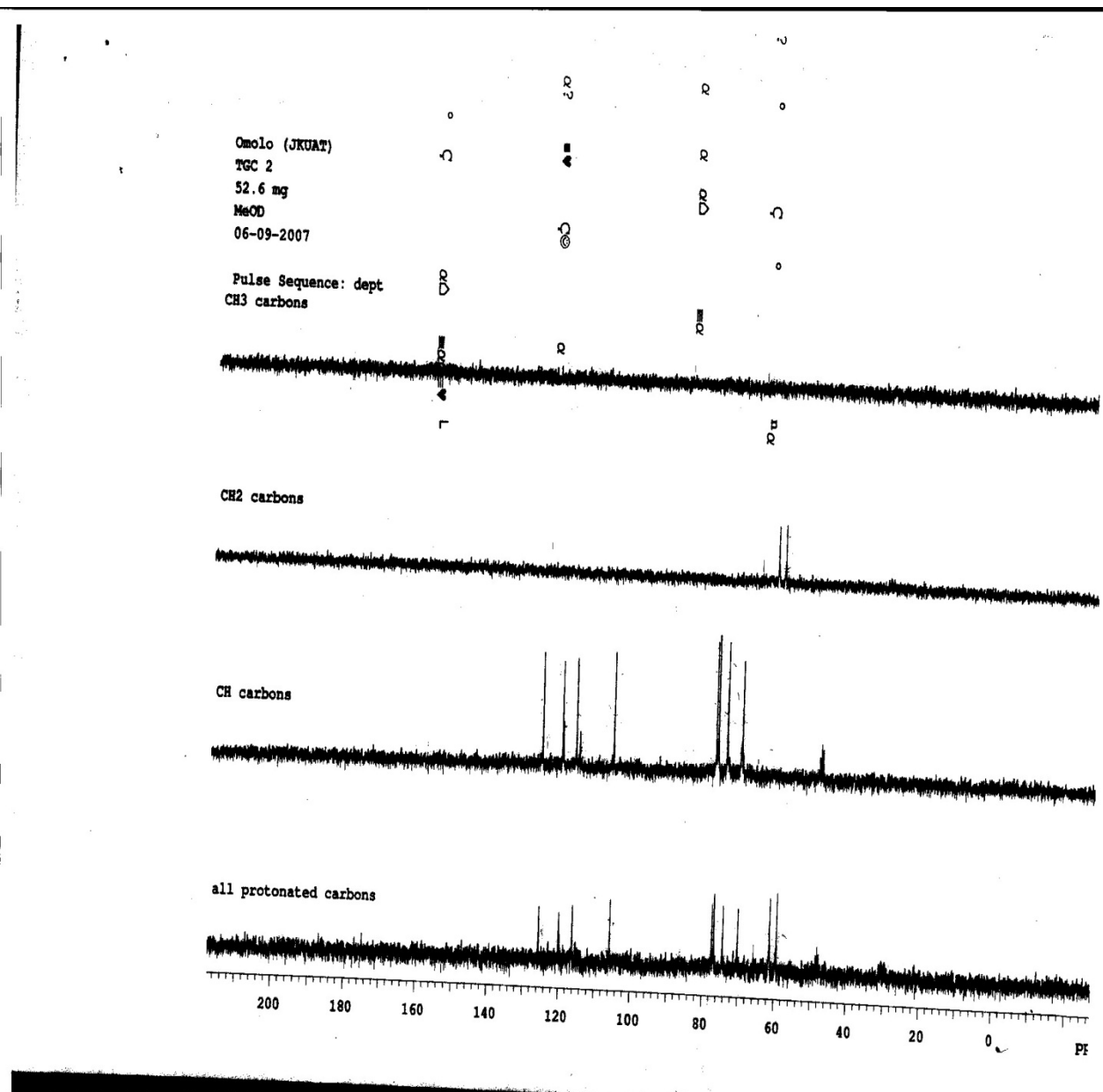

Appendix 5: HMQC NMR spectrum of Idesin [6-hydro-2-(hydroxymethyl)phenyl  $\beta$ -D-glucopyranoside] (61)

Omolo (JKUAT)  
TGC 2  
52.6 mg  
MeOD  
06-09-2007

Pulse Sequence: hetcor  
Solvent: ch3oh  
Ambient temperature  
Mercury-200 "uonmr200"

PULSE SEQUENCE: hetcor  
Relax. delay 1.000 sec  
Acq. time 0.082 sec  
Width 12500.0 Hz  
2D Width 3000.3 Hz  
256 repetitions  
128 increments  
OBSERVE C13, 50.2839375 MHz  
DECOUPLE H1, 199.9767374 MHz  
Power 31 dB  
on during acquisition  
off during delay  
WALTZ-16 modulated  
DATA PROCESSING  
Line broadening 1.0 Hz  
F1 DATA PROCESSING  
Line broadening 0.3 Hz  
FT size 2048 x 512  
Total time 10 hr, 39 min, 58 sec

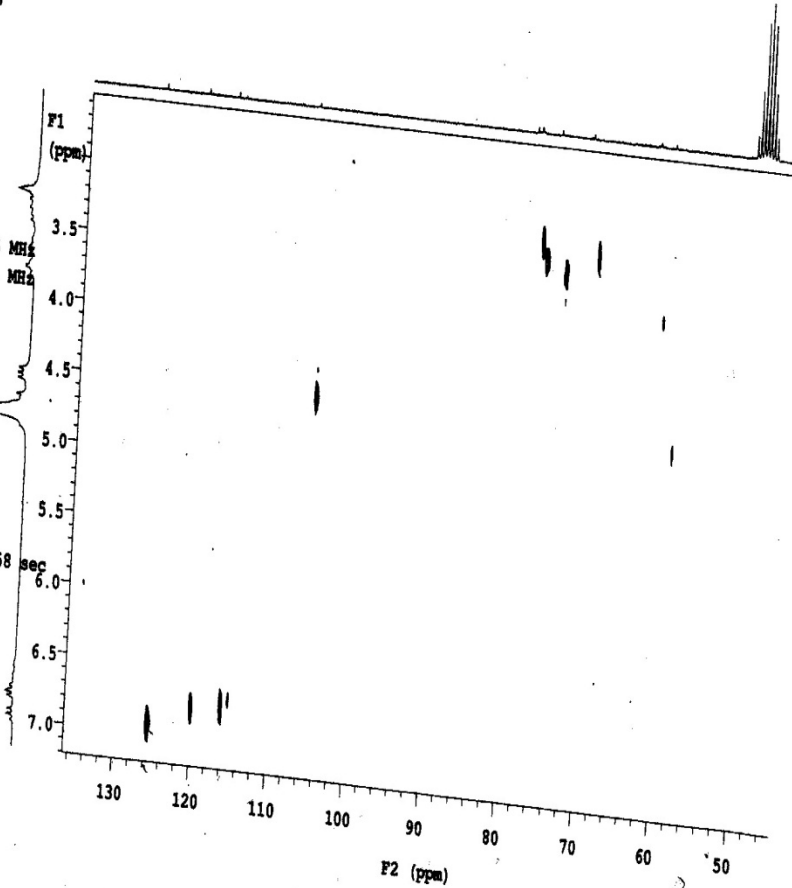

Appendix 6: IR spectrum of Lupenone [Lup-20(29)-en-3-one] TG 4 (62)

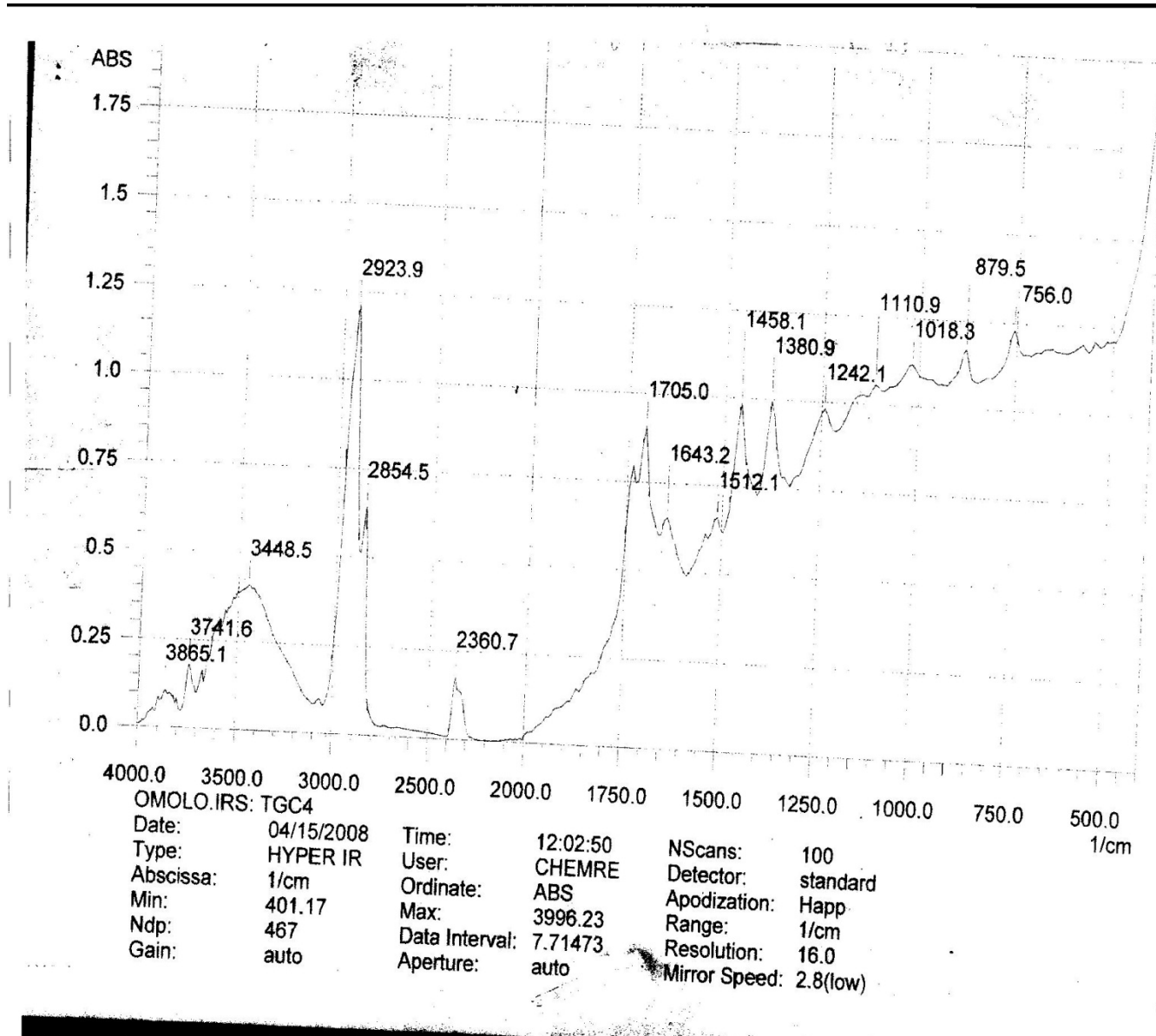

Appendix 7: <sup>1</sup>H-NMR spectrum of Lupenone [Lup-20(29)-en-3-one] TG 4 (62)

200 MHz  
CDCl3  
18-02-2008  
TGC4  
Pulse Sequence: s2pu1

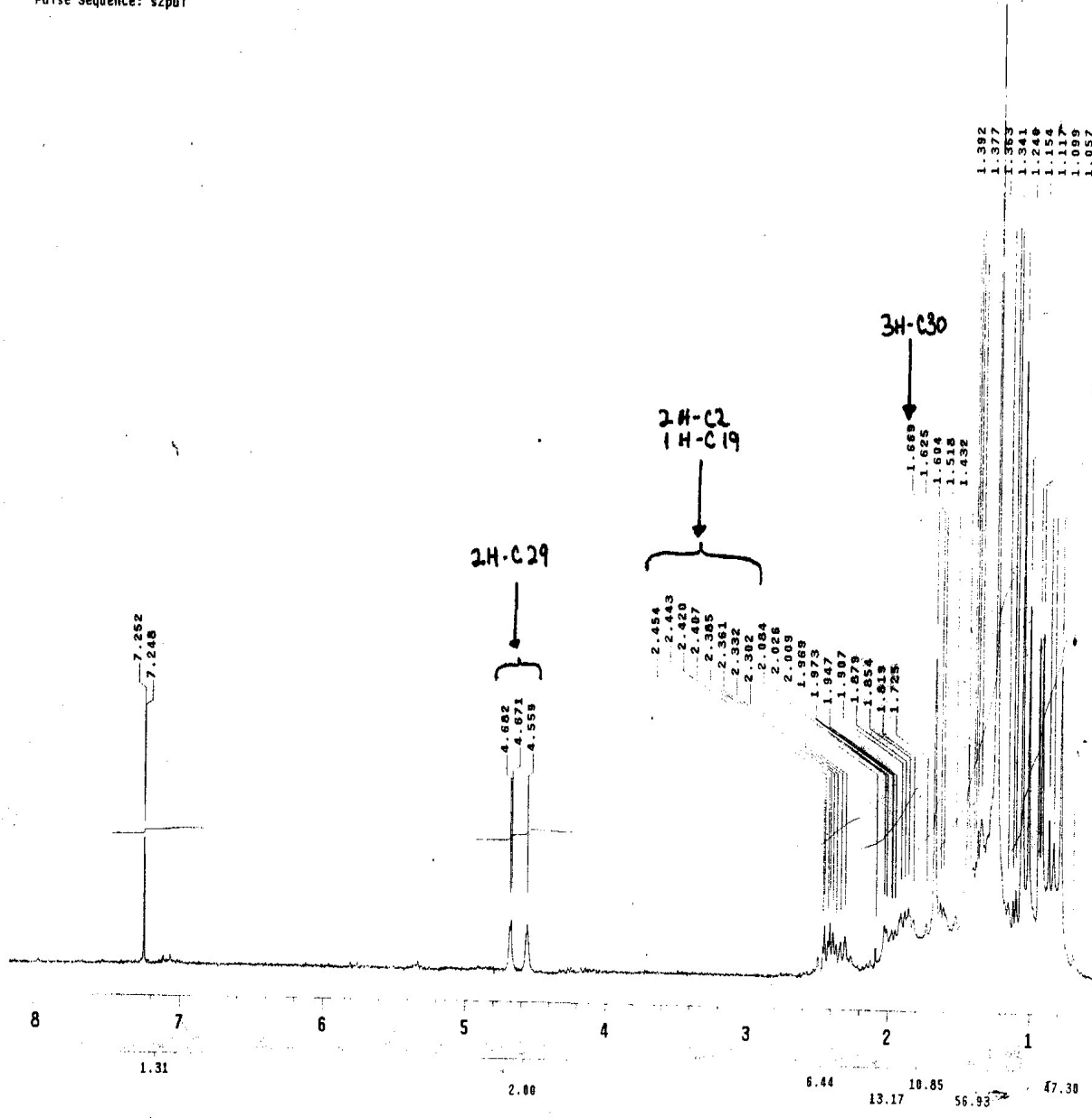

Appendix 8:  $^{13}\text{C}$ -NMR spectrum of Lupenone [Lup-20(29)-en-3-one] TG 4 (62)

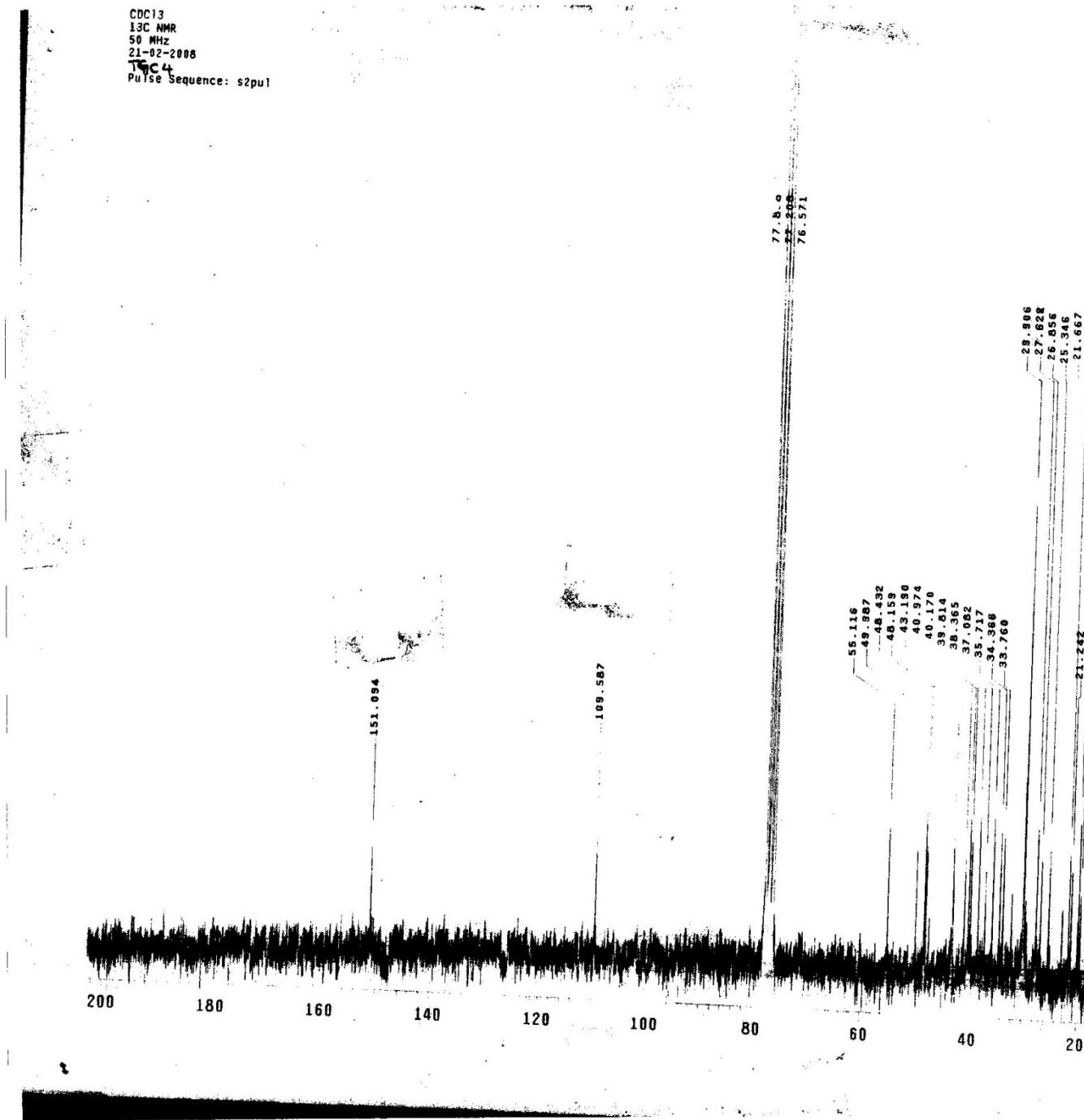

**Appendix 9: IR spectrum of  $\beta$ -sitosterol [ $3\beta$ -stigman-5-en-3-ol] TGP 33 (63)**

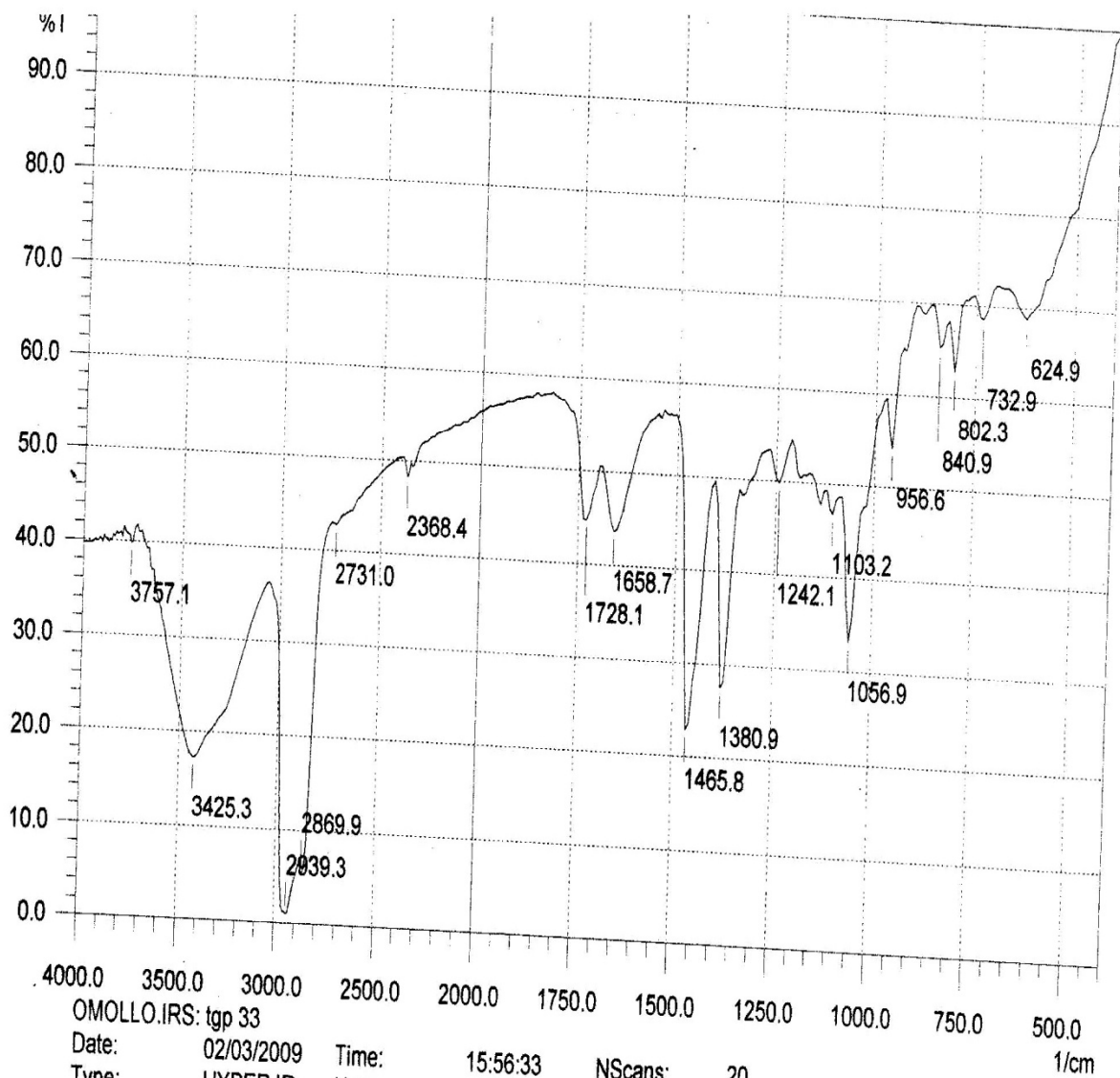

OMOLLO.IRS: tgp 33  
 Date: 02/03/2009 Time: 15:56:33 NScans: 20  
 Type: HYPER IR User: CHEMRE Detector: standard  
 Abscissa: 1/cm Ordinate: %T Apodization: Happ  
 Min: 401.17 Max: 3996.23 Range: 1/cm  
 Ndp: 467 Data Interval: 7.71473 Resolution: 16.0  
 Gain: auto Aperture: auto Mirror Speed: 2.8(low)



Appendix 10: <sup>1</sup>H-NMR spectrum of β-sitosterol [3β-stigman-5-en-3-ol] TGP 33 (63)

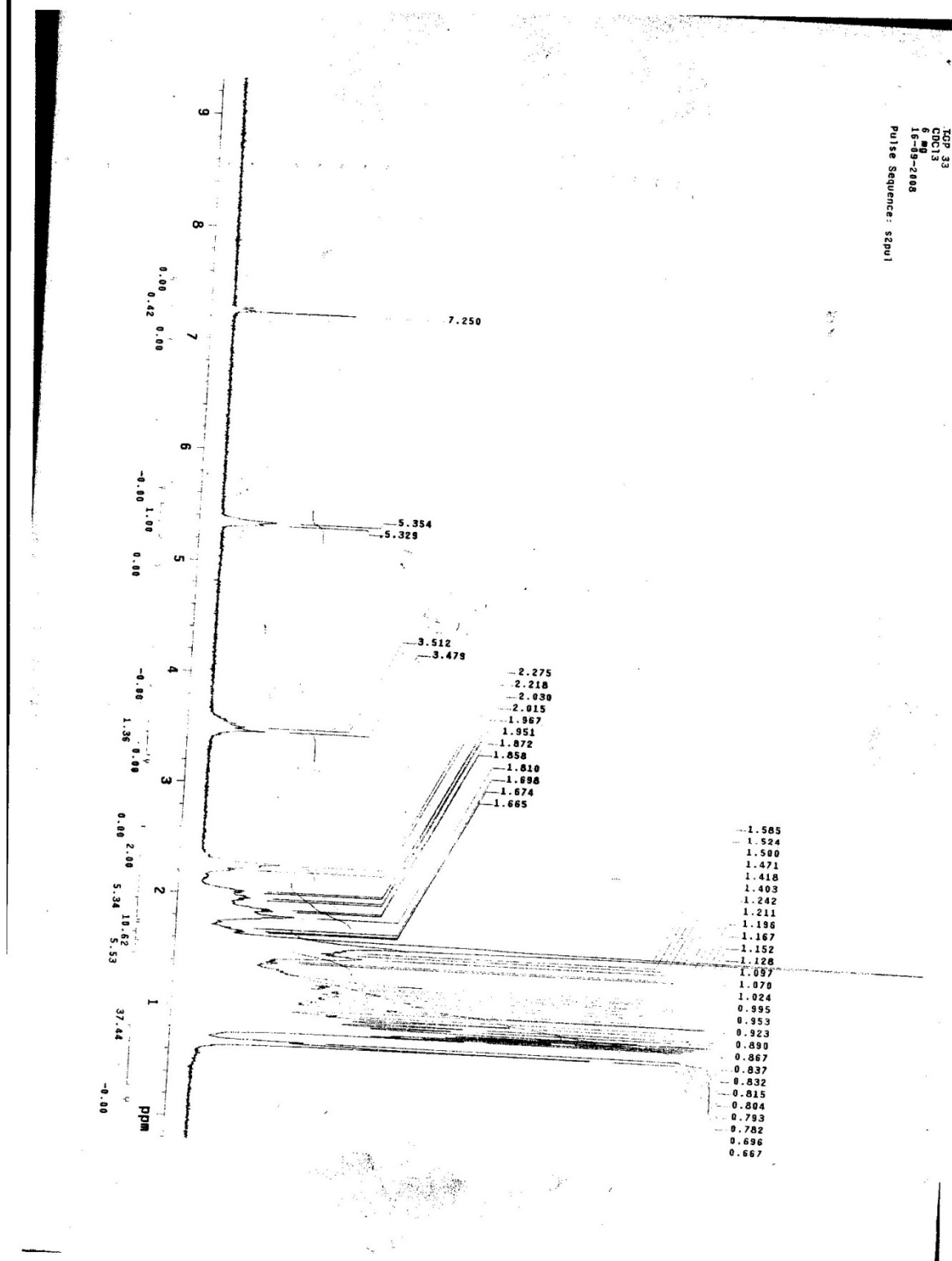

Appendix 11:  $^{13}\text{C}$ -NMR spectrum of  $\beta$ -sitosterol [ $3\beta$ -stigman-5-en-3-ol] TGP 33 (63)

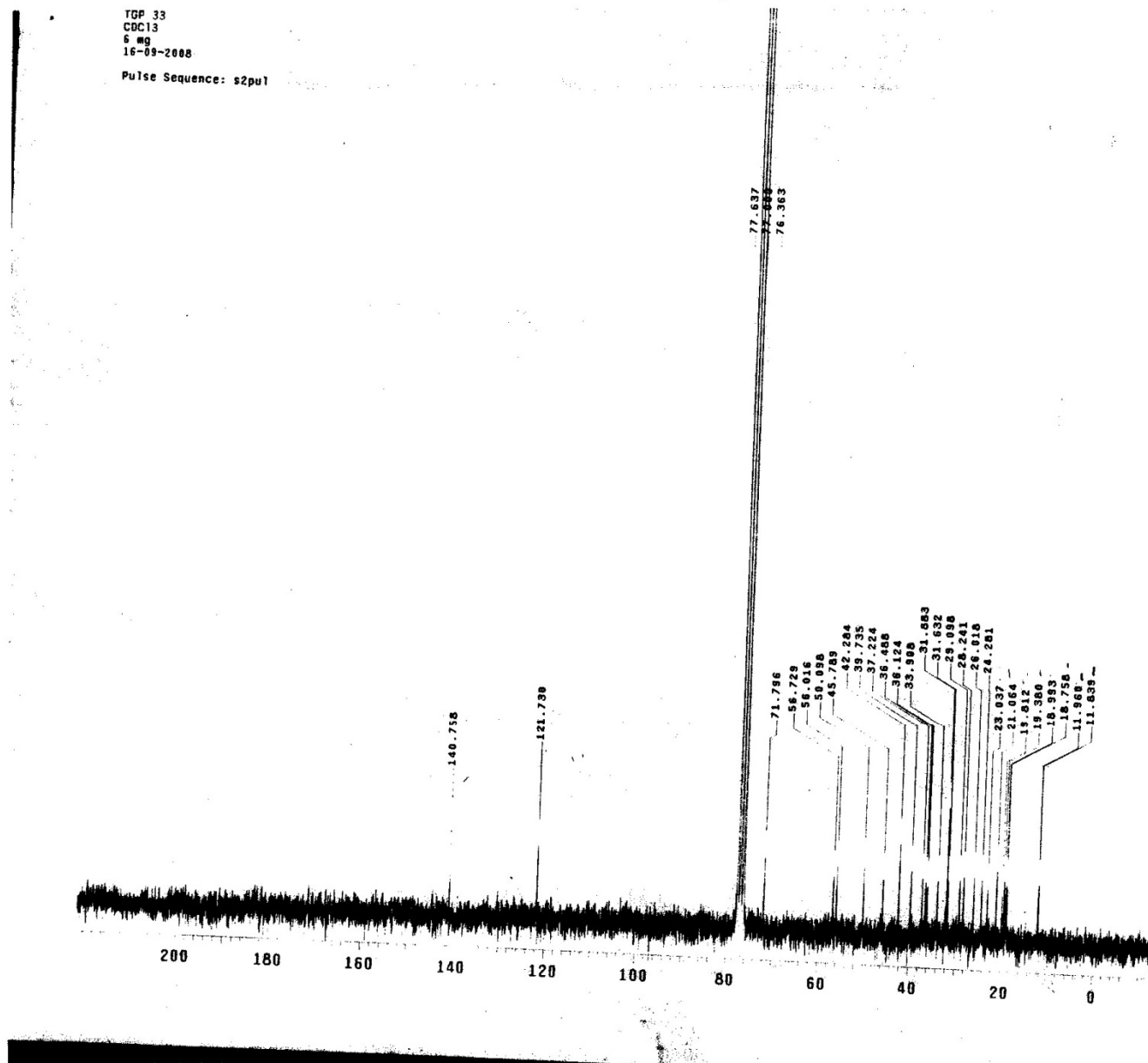

Appendix 12 : DEPT spectrum of  $\beta$ -sitosterol [ $3\beta$ -stigman-5-en-3-ol] TGP 33 (63)

TGP 33  
CDCl<sub>3</sub>  
6 mg  
16-09-2008  
Pulse Sequence: dept

CH3 carbons



CH2 carbons



CH carbons

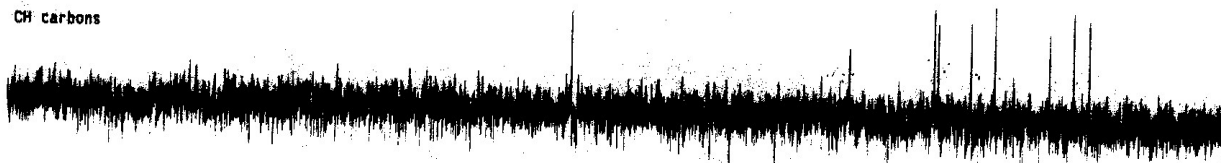

all protonated carbons

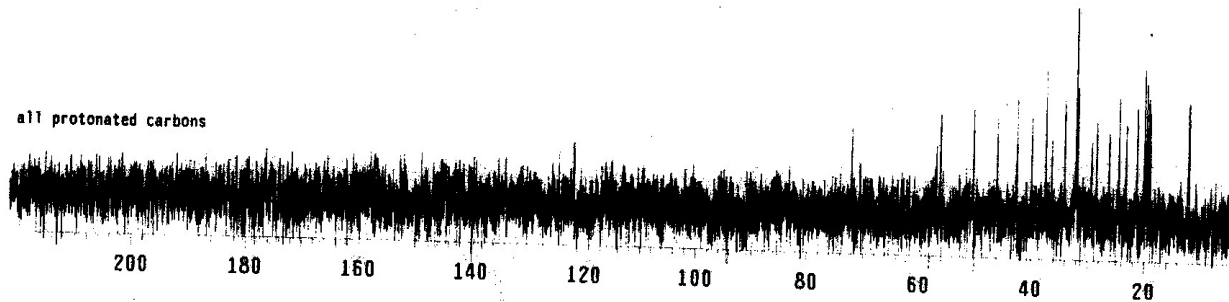

200 180 160 140 120 100 80 60 40 20

Appendix 13: HMQC spectrum of  $\beta$ -sitosterol [ $3\beta$ -stigman-5-en-3-ol] TGP 33 (63)

SGM33  
CDC13  
E6M9-2008  
16-09-2008  
Pulse Sequence: relayh  
Pulse Sequence: hetcor  
Solvent: CDCl<sub>3</sub>  
Ambient temperature  
Mercury-200 "uonmr200"  
PULSE SEQUENCE: relayh  
Relax. delay 1.000 sec  
COSY 90-90  
Acq. time 0.171 sec  
Width 3900.3 Hz  
2D Width 3900.3 Hz  
64 repetitions  
125 increments  
OBSERVE H1, 199.9749906 MHz  
DATA PROCESSING  
F1 DATA PROCESSING  
Line broadening 0.3 Hz  
FT size 1024 x 1024  
Total time 2 hr, 45 min, 42 sec

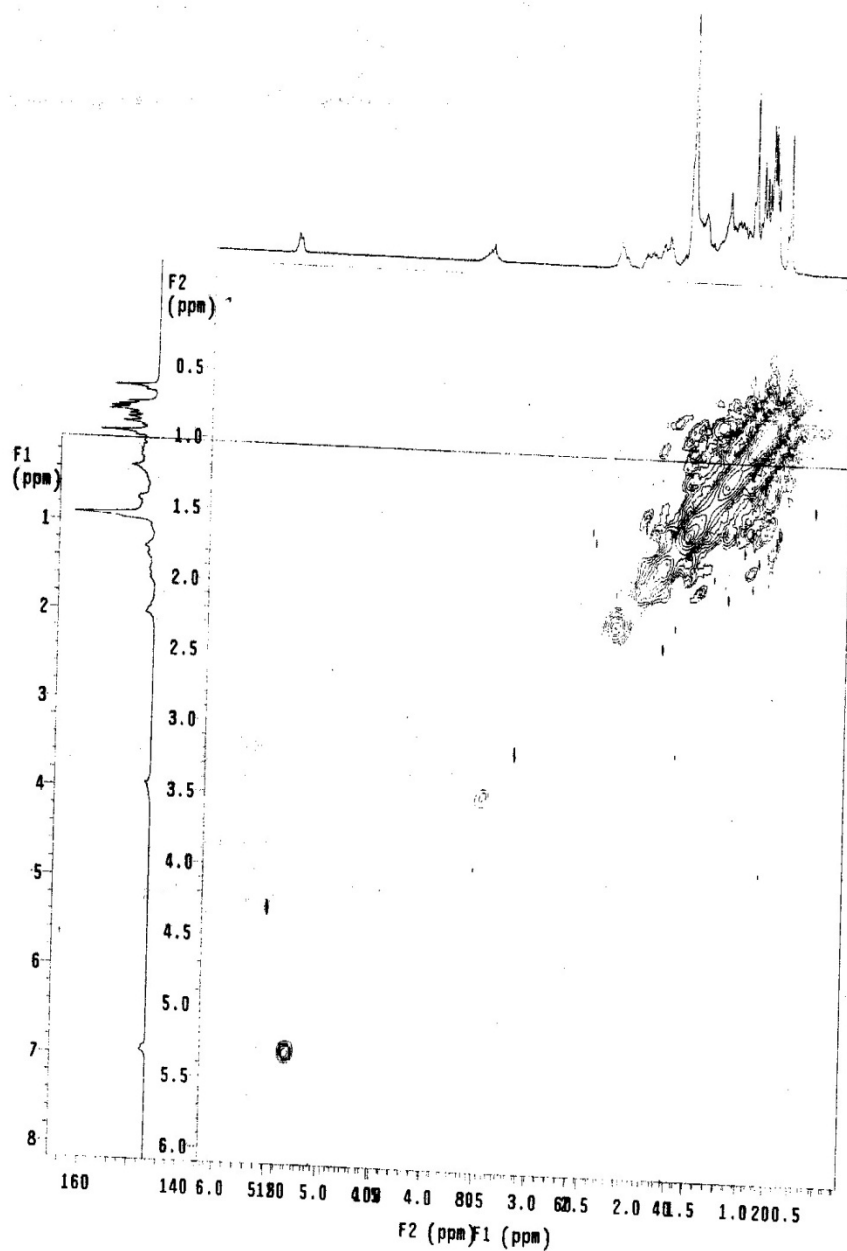

**Appendix 14: IR spectrum of friedelanol MP 24 (64)**

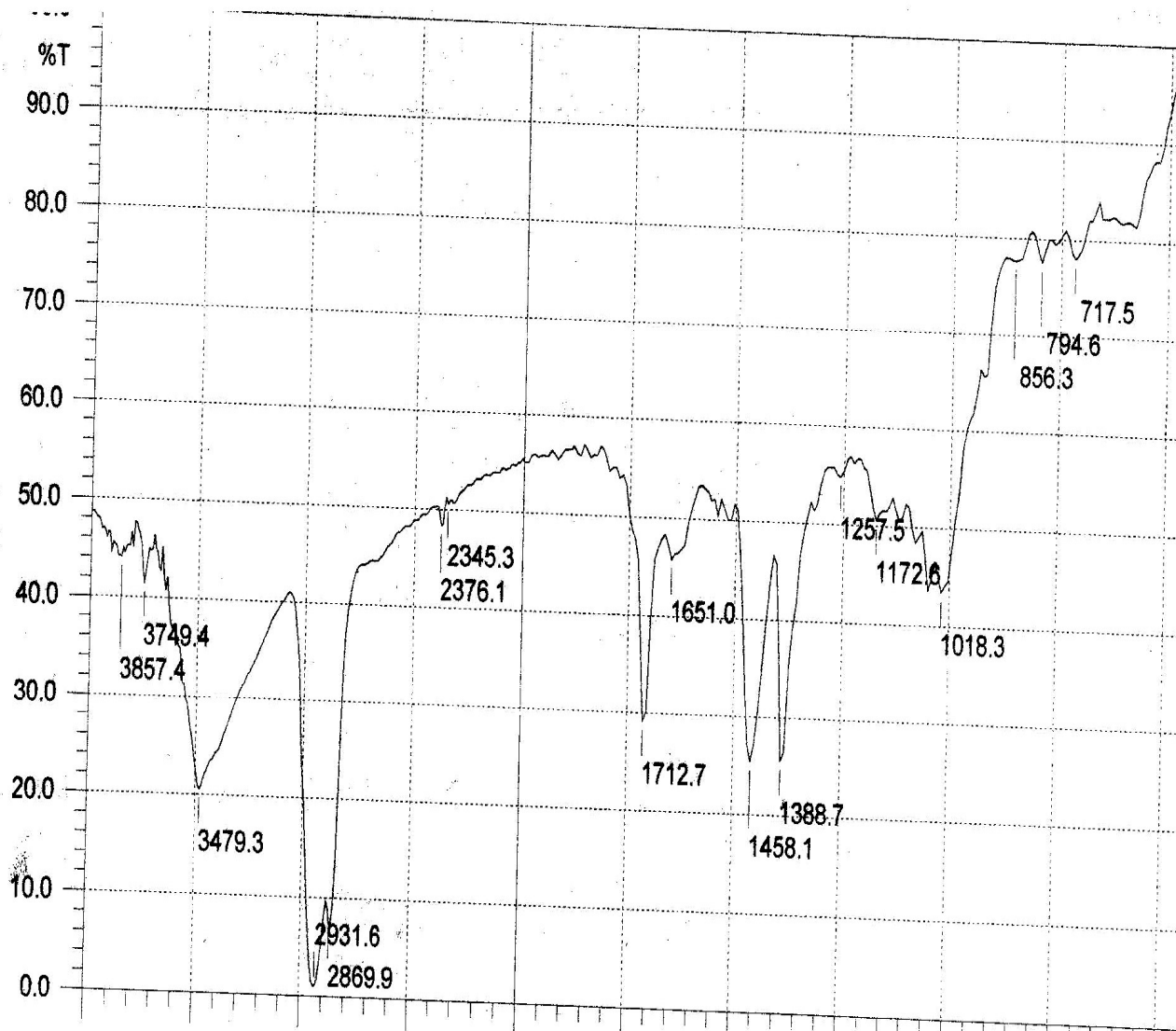

4000.0 3500.0 3000.0 2500.0 2000.0 1750.0 1500.0 1250.0 1000.0 750.0 500.0

OMOLLO.IRS: MP24- SOLID

Date: 02/02/2009	Time: 12:13:09	NScans: 20
Type: HYPER IR	User: CHEMRE	Detector: standard
Abscissa: 1/cm	Ordinate: %T	Apodization: Happ
Min: 401.17	Max: 3996.23	Range: 1/cm
Ndp: 467	Data Interval: 7.71473	Resolution: 16.0
Gain: auto	Aperture: auto	Mirror Speed: 2.8(low)

Appendix 15:  $^1\text{H-NMR}$  spectrum of friedelanol MP 24 (64)

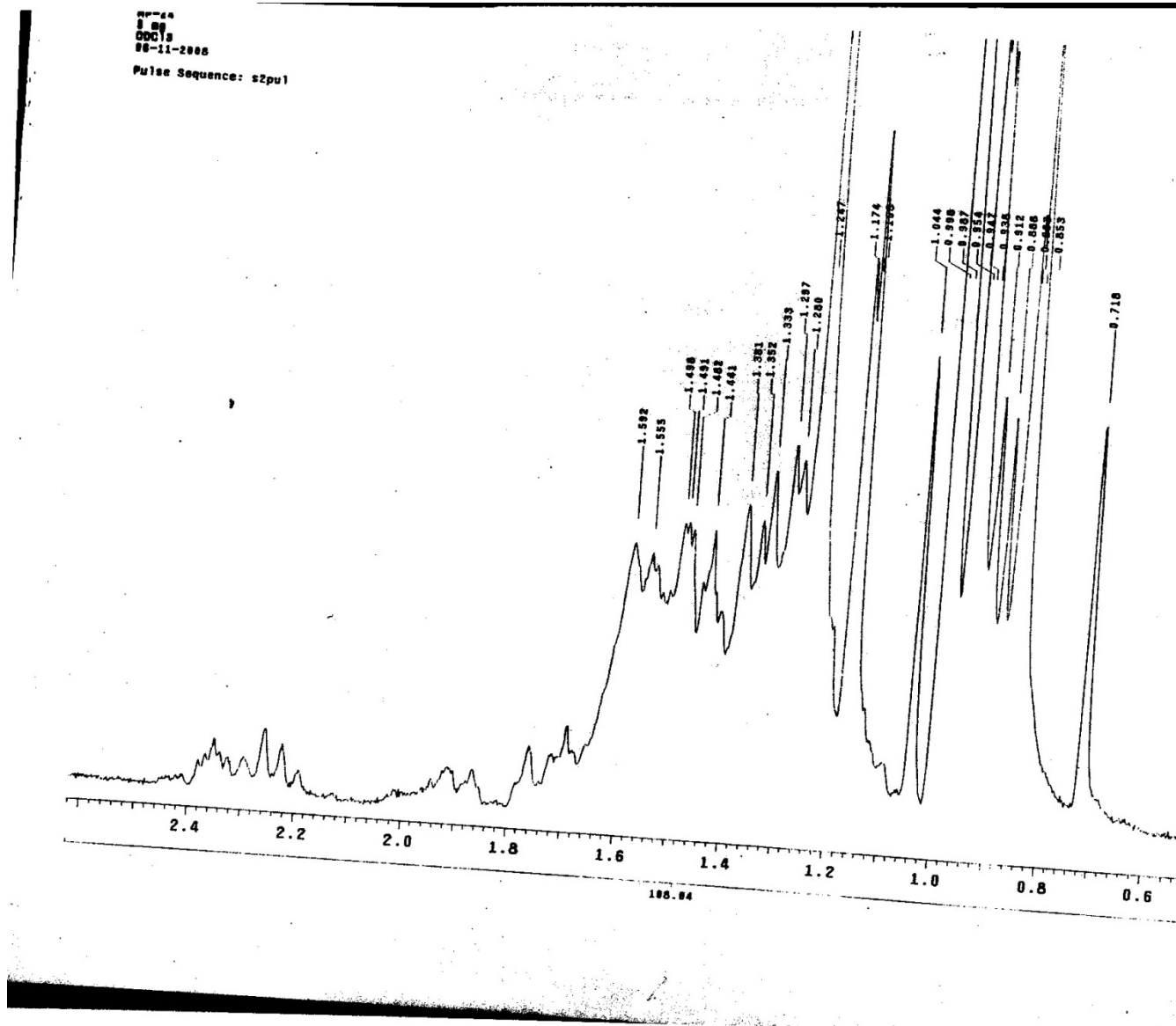

Appendix 16: <sup>13</sup>C-NMR spectrum of friedelanol MP 24 (64)

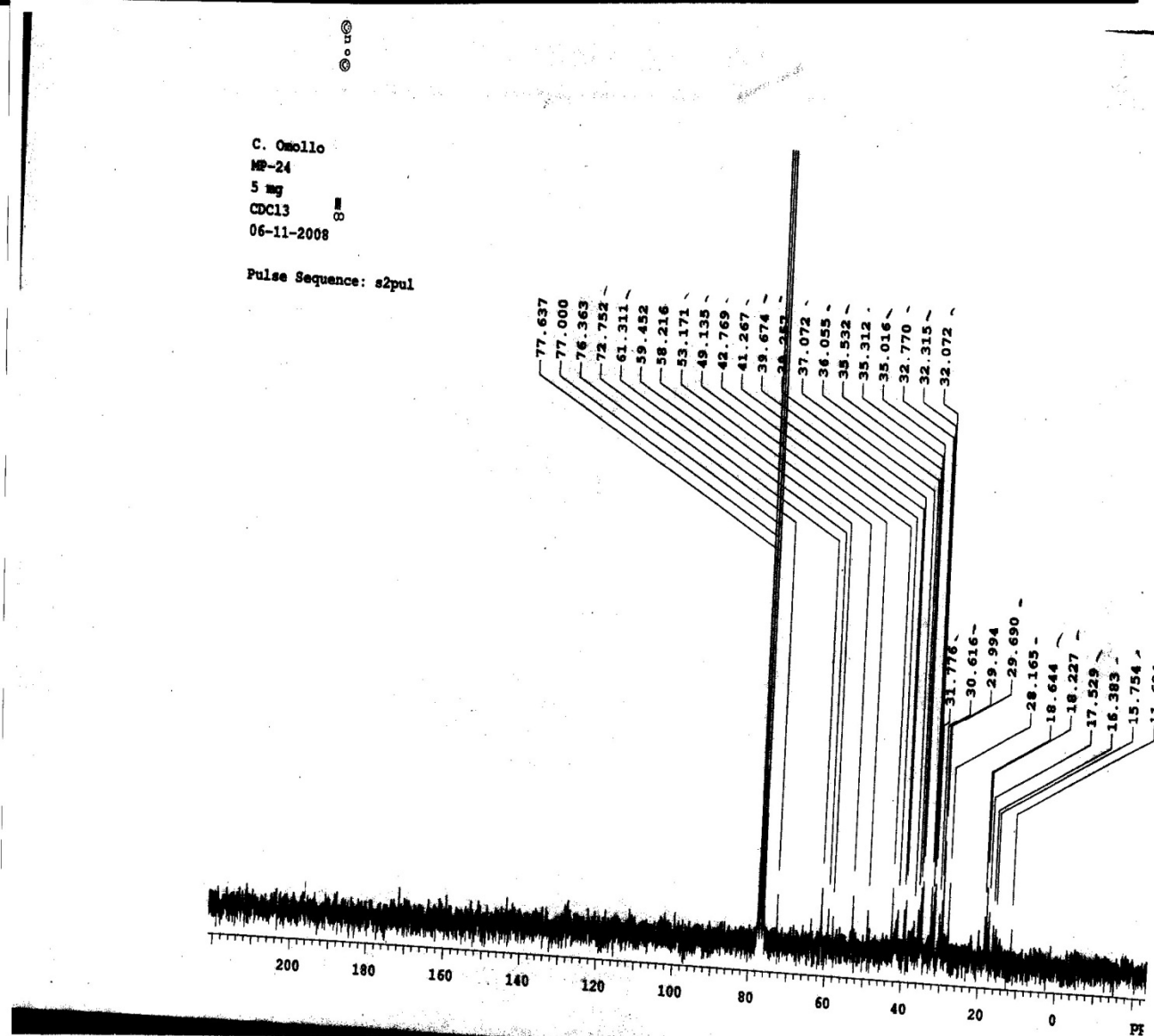

**Appendix 17: DEPT spectrum of friedelanol MP 24 (64)**

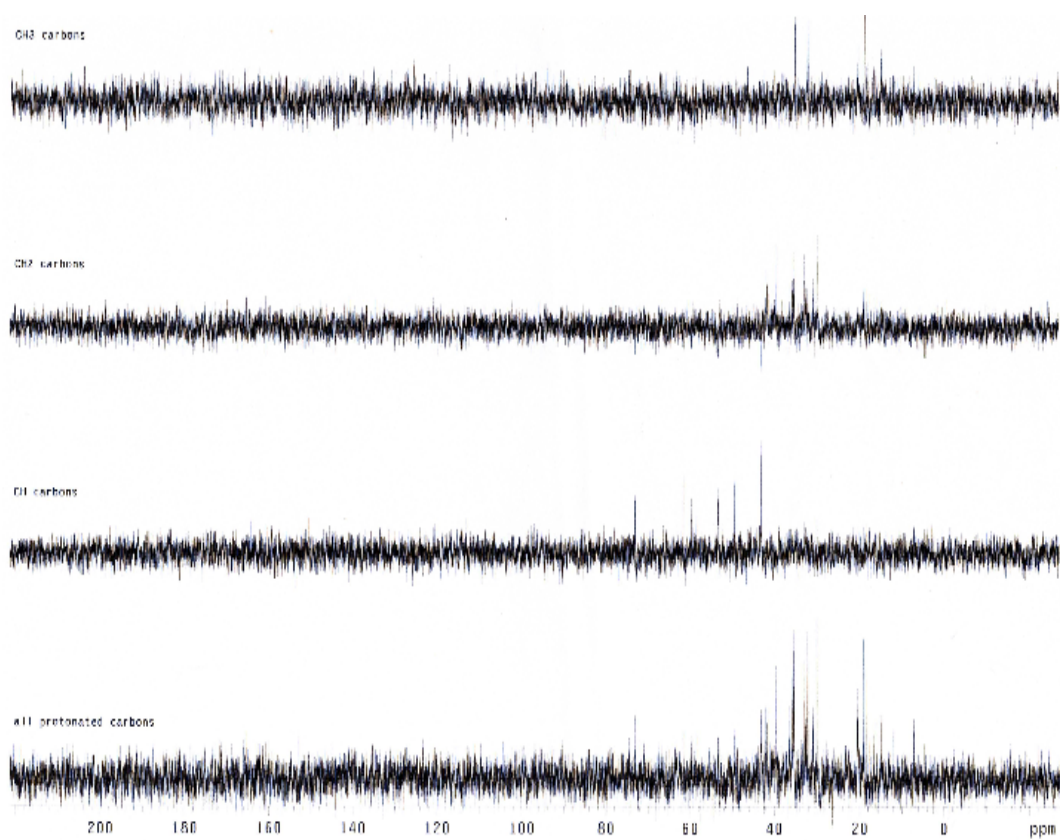



# Appendix 18: HMQC spectrum of friedelanol MP 24 (64)

